

**No. 020-048****GARAGE ASSORTMENT**

Contains 50 Standard and Cup Type Expansion Plugs

Assortment is packed in rigid, transparent plastic box.**No. 020-666****MASTER ASSORTMENT**

Contains 120 Metric Standard and Cup Type Expansion Plugs in 16 popular sizes.

No. 020-633**MASTER ASSORTMENT**

Contains 110 Cup and Shallow Cup Type Expansion Plugs in 18 popular sizes.

No. 020-640**MASTER ASSORTMENT**

Contains 140 Standard and Cup Type Expansion Plugs in 19 popular sizes.

These assortments are packed in metal boxes with high-strength plastic compartments. Features retail price codes on grease-resistant lid label and safety snap-lock handle.**No. 020-800****SUPER-SERVICE ASSORTMENT**

Contains 200 Standard and Cup Type Expansion Plugs in 29 popular sizes.

No. 020-801**SUPER-SERVICE ASSORTMENT**

Contains 170 Cup and Shallow Cup Type Expansion Plugs in 30 popular sizes.

No. 020-840**SUPER-SERVICE ASSORTMENT**

Contains 180 Metric Standard and Cup Type Expansion Plugs in 28 popular sizes.

No. 020-841**SUPER-SERVICE ASSORTMENT**

Contains 150 Metric Cup and Shallow Cup Type Expansion Plugs in 25 popular sizes.

These assortments are packed in large size metal boxes with moulded plastic compartments. Features grease-resistant lid label, safety snap-lock handle and retail price codes.

TROUSSE DE BOUCHON DE ACIER D'EXPANSION**DOMESTIC - IMPORTS - TRUCKS - MARINE**

A time-saving kit for machine shops, engine rebuilders and Jobbers. Expansion plugs for each engine skin-packed in one convenient package. Coverage for Domestic and Import engines.

DOMESTIQUES - IMPORTÉ - CAMIONS - MARINE

Une trousse qui épargne du temps aux ateliers de mécanique, reconSTRUCTEURS de moteurs et revendeurs. Les bouchons d'expansion sont emballés sous un emballage moulant protique. Ils servent aux moteurs domestiques et importés.

Year	Cyl.	Application	Kit No.
AMC			
1996-97	(V6)	4.0L (242) M, L, S	260-401
1988-71	(V6)	4.2L (258)	260-402

BUICK			
1989-82	(4)	1.8L (112J,O), 2.0L (121)	260-418
1992-80	(4)	2.5L (151)	260-400
1989-80	(V6)	2.8L (173) W, X, Y, Z	260-407
2005-85	(V6)	3.0L (181) E, L 3.8L (231) A, B, G, 2, 3, 7, 8, 9	260-406
1992-77	(V8)	5.0L (305)	260-425
1990-80	(V8)	5.0L (307) Y, 4.3L (260) Diesel, 5.7L (350) N Diesel	260-413

CADILLAC			
1992-88	(V6)	4.5L (273)	260-415
1993-86	(V8)	5.0L (307) Y, 5.7L (350) N Diesel	260-413

CHEVROLET			
2002-90	(4)	2.2L (134)	260-425
1992-78	(4)	2.5L (151)	260-400
1989-80	(V6)	2.8L (173) W, X, Z, I	260-407
2005-88	(V6)	3.8L (231) I, K, L	260-410
1990-85	(V6)	4.3L (262)	260-413
1993-91	(V6)	4.3L (262) Z	260-412
1996-57	(V8)	265, 267, 283, 302, 305, 307, 327, 350 to 1996	260-425

CHEVY/GMC			
1993-82	(V6)	2.8L (173)	260-407
2005-85	(V6)	4.3L (262) N, Z	260-412
1989-63	(V6)	4.8L (292)	260-415
2002-76	(V8)	5.0L (305), 5.0L (307), 5.4L (327)	260-425
2002-73	(V8)	5.7L (350)	260-425
2000-70	(V8)	6.0L (366), 7.4L (454)	260-426
2002-82	(V8)	6.2L (379) Diesel, (395) Diesel	260-421

Year	Cyl.	Application	Kit No.
CHRYSLER/DODGE			
1993-82	(4)	2.2L (135) OHC, 2.5L (153) OHC	260-434
1995-88	(V6)	3.0L (181)	260-430
2005-94	(V6)	3.3L (201)	260-436
2005-90	(V6)	3.3L (201), 3.5L (215), 3.8 (230)	260-432

FORD/FORD TRUCK			
1994-84	(4)	2.3L (140) OHC	260-446
2005-86	(V6)	3.0L (182) exc. SHO engine	260-448
2004-82	(V6)	3.8L (232)	260-442
1996-65	(V6)	4.9L (300, 300) LD	260-450
2005-97	(V8)	4.6L (281)	260-457
2001-68	(V8)	4.7L (289), 5.0L (302), 5.8L (351) W	260-451
1997-87	(V8)	5.8L (351), C, M, 6.6L (401)	260-454
1997-73	(V8)	6.1L (370), 7.0L (429), 7.5L (460)	260-455

OLDSMOBILE			
1995-89	(4)	2.3L (138)	260-418
1992-78	(4)	2.5L (151) 1, 5, 9, R, V	260-400
1989-79	(V6)	2.8L (173) W, X, Z	260-407
2000-88	(V6)	3.0L (181) E, L, 3.8L (231) A, B, C, 2, 3, 4.1L (252)	260-410
2001-91	(V8)	4.3L (260) F, 8, 4.3L (260) Diesel, 5.0L (307) Y, 5.7L (350) R, 5.7L (350) N Diesel	260-413
1992-77	(V8)	4.4L (267) J, 5.0L (305) 350 G, L	260-425

PONTIAC			
1991-87	(4)	1.8L (112) J, O, OHC, 112G, 2.0L (122) B, K, M, P	260-418
1991-77	(4)	2.5L (151) F, R, U, V, 1, 2, 5, 9	260-400
1989-79	(V6)	2.8L (173) L, S, W, X, Z, 1, 7, 9	260-407
1996-85	(V6)	3.0L (181) E, L, 3.8L (231) A, B, C, 2, 3, 4.1L (252)	260-410
1992-77	(V8)	5.0L (305), 5.7L (350L)	260-425
1992-87	(V8)	5.7L (350R), 5.7L (350N) Diesel, 6.6L (403)	260-413

BOUCHON D'EXPANSION

Also known as Frost Plugs, Welsh Plugs or Freeze-Out Plugs. "Papco" Expansion Plugs are made of heavy gauge plated steel or solid brass to resist rust.

Aussi connus "Frost Plugs"; "Welsh Plugs"; "Freeze-Out Plugs". Les bouchons d'expansion "Papco" sont fabriqués d'acier épais et plaqués au laiton massif pour résister à la rouille.

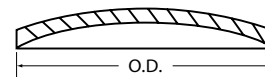
**STANDARD TYPE TYPE REGULIER**Standard Package / Contenant Régulier: $3/8 - 1\ 5/8 = 25$ pcs. $1\ 47/64 - 3 = 12$ pcs.

Stock No. STEEL	Stock No. BRASS	Nominal Plug Size	Reference O.D. +/- .005
260-006	260-506	3/8	.375
260-008		7/16	.437
260-010	260-510	1/2	.500
260-012		9/16	.563
260-014		5/8	.625
260-016		1 11/16	.687
260-018	260-518	3/4	.750
260-020		13/16	.812
260-022		27/32	.844
260-024	260-524	7/8	.875
260-026	260-526	15/16	.936
260-028	260-528	1	1.000
260-030	260-530	1 1/32	1.031
260-032	260-532	1 1/16	1.063
260-034	260-534	1 1/8	1.125
260-036	260-536	1 3/16	1.188
260-039	260-539	1 1/4	1.250

Stock No. STEEL	Stock No. BRASS	Nominal Plug Size	Reference O.D. +/- .005
260-042		1 5/16	1.313
260-045	260-545	1 3/8	1.375
260-048	260-548	1 7/16	1.437
260-051	260-551	1 31/64	1.484
260-054		1 1/2	1.500
260-057	260-557	1 5/8	1.625
260-060		1 47/64	1.734
260-063	260-563	1 3/4	1.750
260-066	260-566	1 7/8	1.875
260-069	260-569	2	2.000
260-072		2 1/16	2.063
260-075	260-575	2 7/64	2.105
260-078	260-578	2 1/4	2.250
260-081		2 1/2	2.500
260-084		2 3/4	2.750
260-087		3	3.000

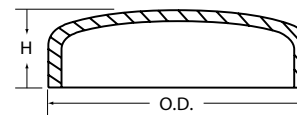
**CUP TYPE TYPE D'ASSIETTE**

Standard Package / Contenant Régulier: =12 pcs.

Plated Steel or Solid Brass / Acier Plaqué ou laiton massif

Stock No. STEEL	Stock No. BRASS	Nominal Plug Size	Reference O.D. +/- .005	H-Overall Height
260-100		1/4	.260	.135
260-103		5/16	.3135	.296
260-105		3/8	.385	.240
260-108		7/16	.450	.210
260-110	260-610	7/16	.4445	.156
260-111		25/64	.404	.265
260-112		29/64	.460	.270
260-113		15/32	.475	.200
260-114		1/2	.527	.312
260-115		1/2	.511	.258
260-116		35/64	.5425	.250
260-117		33/64	.512	.248
260-118		9/16	.583	.250
260-120		19/32	.594	.281
260-121		9/16	.571	.250
260-125		21/32	.658	.266
260-126	260-626	5/8	.6325	.250
260-127		43/64	.662	.235
260-128		11/16	.700	.250
260-129		41/64	.635	.233
260-130	260-630	3/4	.7525	.250
260-132		3/4	.7625	.265
260-133		51/64	.789	.312

Stock No. STEEL	Stock No. BRASS	Nominal Plug Size	Reference O.D. +/- .005	H-Overall Height
260-134		13/16	.812	.312
260-136		7/8	.888	.312
260-138	260-638	29/32	.912	.390
260-140	260-640	59/64	.925	.335
260-141		7/8	.869	.312
260-142		15/16	.945	.375
260-143		61/64	.951	.272
260-144	260-644	1	1.014	.281
260-145		1	1.009	.295
260-146		1 1/16	1.073	.280
260-147		1 5/64	1.072	.280
260-150	260-650	1 1/8	1.133	.437
260-153		1 13/64	1.200	.420
260-156		1 7/32	1.228	.531
260-159	260-659	1 1/4	1.255	.300
260-162*		1 1/4	1.2575	.343
260-165		1 1/4	1.258	.437
260-168		1 3/8	1.3875	.500
260-171		1 7/16	1.438	.431
260-174		1 1/2	1.522	.375
260-177		1 1/2	1.506	.325
260-180	260-680	1 1/2	1.5075	.625
260-183		1 9/16	1.576	.600

* With Reverse Taper

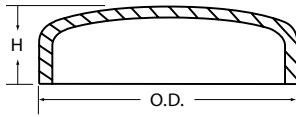
**CUP TYPE** **TYPE D'ASSIETTE** Standard Package / Contenant Régulier: =12 pcs.

Plated Steel or Solid Brass / Acier Plaqué ou laiton massif

Cond't

Stock No. STEEL	Stock No. BRASS	Nominal Plug Size	Reference O.D. +/- .005	H-Overall Height
260-186	260-686	1 5/8	1.6375	.593
260-189		1 41/64	1.642	.350
260-192*		1 45/64	1.7075	.812
260-193		1 45/64	1.638	.350
260-194	260-694	1 3/4	1.7625	.363
260-198	260-698	1 3/4	1.7625	.593
260-204		1 3/4	1.750	.356
260-207	260-707	1 49/64	1.7655	.406
260-210	260-710	1 7/8	1.8925	.447
260-213		1 57/64	1.883	.266
260-216		1 29/32	1.902	.600
260-219	260-719	1 15/16	1.9475	.800
260-222	260-722	1 61/64	1.9555	.718
260-224		1 61/64	1.956	.295

Stock No. STEEL	Stock No. BRASS	Nominal Plug Size	Reference O.D. +/- .005	H-Overall Height
260-225		1 63/64	2.000	.800
260-228	260-728	2	2.009	.635
260-231		2	2.008	.415
260-234	260-734	2 1/64	2.0175	.590
260-237	260-737	2 1/16	2.0675	.510
260-240		2 3/32	2.0975	.610
260-243	260-743	2 1/8	2.145	.430
260-246		2 9/64	2.1485	.600
260-249		2 3/16	2.199	.360
260-252	260-752	2 1/4	2.265	.812
260-255		2 17/64	2.264	.355
260-260		2 1/2	2.504	.350
260-262		2 1/2	2.500	.340

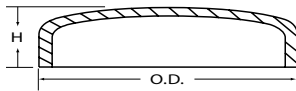
**SHALLOW CUP TYPE** **TYPE D'ASSIETTE PEU PROFOND** Standard Package / Contenant Régulier: =12 pcs.

Plated Steel or Solid Brass / Acier Plaqué ou laiton massif

Stock No. STEEL	Stock No. BRASS	Nominal Plug Size	Reference O.D. +/- .005	H-Overall Height
260-303	260-803	7/16	.440	.170
260-305		29/64	.450	.203
260-307		1/2	.505	.250
260-308		17/32	.541	.187
260-309		35/64	.5425	.187
260-311		5/8	.631	.190
260-312		45/64	.700	.205
260-313		53/64	.8235	.250
260-315	260-815	1	1.010	.290
260-318	260-818	1 1/4	1.2625	.312
260-321		1 21/64	1.3225	.281
260-324	260-824	1 3/8	1.385	.340
260-327	260-827	1 1/2	1.505	.300
260-330		1 9/16	1.570	.315
260-333	260-833	1 5/8	1.640	.345
260-336		1 45/64	1.703	.281
260-339	260-839	1 3/4	1.762	.232
260-342		1 51/64	1.8025	.250

Stock No. STEEL	Stock No. BRASS	Nominal Plug Size	Reference O.D. +/- .005	H-Overall Height
260-345		1 53/64	1.825	.350
260-348		1 29/32	1.915	.265
260-351		1 59/64	1.922	.235
260-354		1 31/32	1.9775	.218
260-357		2	2.025	.406
260-359	260-859	2	2.010	.310
260-362		2 1/64	2.0175	.240
260-365	260-865	2 1/16	2.0725	.343
260-366		2 1/16	2.062	.343
260-372		2 7/64	2.109	.310
260-375		2 9/64	2.135	.360
260-378		2 5/32	2.1535	.328
260-381	260-881	2 3/16	2.200	.355
260-383		2 3/16	2.192	.343
260-385		2 7/32	2.2205	.305
260-388		2 1/4	2.262	.350
260-391		2 3/8	2.385	.312
260-394*		2 9/16	2.575	.301

* With Reverse Taper

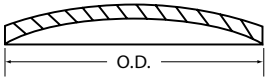
**STANDARD TYPE****TYPE REGULIER** Plated Steel / Acier Plaqué

Standard Package / Contenant Régulier: =10 pcs.

Stock No.	Nominal O.D.	Stock No.	Nominal O.D.
261-011	16 mm	261-064	40 mm
261-014	18 mm	261-069	42 mm
261-024	24 mm	261-077	45 mm
261-026	25 mm	261-090	52 mm
261-046	35 mm	261-096	55 mm

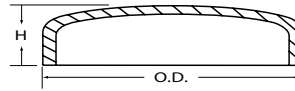
**SHALLOW CUP TYPE****TYPE D'ASSIETTE PEU PROFOND** Plated Steel / Acier Plaqué

Standard Package / Contenant Régulier: =10 pcs.

Stock No.	Nominal O.D.	Stock No.	Nominal O.D.
261-326	25 mm	261-367	42 mm
261-347	35 mm	261-377	45 mm
261-364	40 mm		

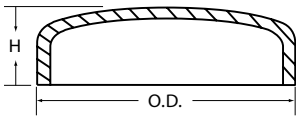
**CUP TYPE** **TYPE D'ASSIETTE**

Standard Package / Contenant Régulier: =10 pcs.

Stock No.	Nominal O.D.	H - Nominal Height (mm)
261-100	8 mm	4.2
261-103	11 mm	4.85
261-105	12 mm	5.3
261-107	14 mm	5.0
261-108	14.4 mm	5.5
261-109	15 mm	5.5
261-111	16 mm	9.1
261-114	18 mm	5.9
261-117	20 mm	7.0
261-118	20 mm	
261-121	22 mm	7.5
261-124	24 mm	6.9
261-126	25 mm	8.3
261-129	27 mm	8.4
261-132	28 mm	8.7
261-135	29 mm	11.4
261-138	30 mm	8.1
261-140	31.5 mm	8.5
261-142	32 mm	9.5
261-145	34 mm	12.7

Stock No.	Nominal O.D.	H - Nominal Height (mm)
261-146	35 mm	10.6
261-149	36 mm	8.5
261-150	36.5 mm	9.0
261-152	37 mm	10.6
261-155	38 mm	7.9
261-158	39 mm	9.5
261-161	40 mm	11.7
261-162	40 mm	12.8
261-165	41 mm	11.9
261-170	42.3 mm	10.0
261-171	42.6 mm	10.0
261-173	44 mm	11.9
261-177	45 mm	11.9
261-178	45 mm	13.5
261-181	47 mm	7.4
261-182	48 mm	11.7
261-184	49.5 mm	11.0
261-185	50 mm	12.0
261-186	50 mm	14.8
261-188	51 mm	5.55



A-new Expansion Plug designed to save Mechanic's time ... will save hours of repair time in replacing core hole plugs, by simply tightening, even when Starter, Generator, Distributor, Manifold, Steering Linkage or Air Conditioner Components interfere.

- Slips in easily.
- Can be finger-tightened.
- Permanently set with open end wrench.
- No metal comes in contact with the coolant.
- Body of plug is specially compounded Neoprene, resistant to heat, antifreeze, and rust inhibitors.
- Expands as much as 1/8" to seal tightly against irregularities.

EXPANSION PLUGS

Order by Stock Number

Stock No.	Size	Metr. Equiv.
263-548	3/4	19 mm
263-556	7/8	22 mm
263-564	1"	25 mm
263-572	1 - 1/8	29 mm
263-580	1 - 1/4	32 mm

Stock No.	Size	Metr. Equiv.
263-588	1 - 3/8	35 mm
263-596	1 - 1/2	38 mm
263-604	1 - 5/8	41 mm
263-612	1 - 3/4	45 mm

Stock No.	Size	Metr. Equiv.
263-620	1 - 7/8	48 mm
263-628	2"	51 mm
263-636	2 - 1/8	54 mm
263-644	2 - 1/4	57 mm

OIL DRAIN PLUGS

Stock No.	Size	Metr. Equiv.
'E-Z' SEAL OIL DRAIN PLUGS		
263-290	7/16	12 mm
263-320	1/2	13 mm
263-322	9/16	14 mm
263-400	5/8	16 mm

- Install dry.
- Do not use sealer.
- Do not use where petroleum products contact rubber.
- Do not overtighten.
- *Installe a sec.*
- *L'employer pas d'adhésive*
- *L'employer pas ou des produits pétroleum d'evientront en contact avec le néoprène.*
- *Ne pas trois serre.*

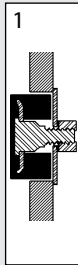

- Make sure washer and nut are loose.
Faire certain que la rondelle et l'ecroux ne sont pas serré.
- Washer must be flush with side of wall before and after plug is installed.
La rondelle doit être égale avec le côté du mur avant d'être installé.
- Plug must extend 1/4" beyond inside wall to allow a ridge to form.
Le tampons doit dépassé le mur intérieure d' au moins 1/4 de pouce pour permettre la formation d'un coussin.
- Turn the nut clockwise 2 or 3 turns to form a ridge and properly set plug.
Pour bien placé ce tampon, serré l'ecrou de 2 ou 3 tours.
- When properly installed plug will hold pressure to 50 P. S. I.
Quand bien posée un tampon soutiendra une pressions de 50 P. S. I.

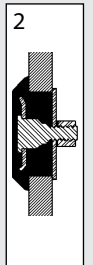

MERCHANDISER No. 022-123

Includes Rack, Header Sign, Inventory Control, Planogram and a 20 card stock of 'E-Z Seal Plugs' listed above.



ASSORTMENT No. 020-318

Contains 13 'E-Z Seal' Expansion Plugs - one of each size. Have every size on Hand - repair leaking metal frost plugs in all locations - whether hard or easy to get to.

Contient 13 bouchons d'expansion 'E-Z Seal' - un de chaque format. Ayez tous les formats en main. Réparez les bouchons en métal protégeant contre la gelée à tous les endroits - difficiles ou faciles à rejoindre.



Use 'E-Z Seal' for Inch and Metric applications

papeo EXPANSION PLUGS

BOUCHON D'EXPANSION

ENGINE SIZE (C.I.D.) FORMAT DE MOTEUR	YEAR ANNEE	BLOCK BLOC	CAMSHAFT ARBE A CAME	CYLINDER HEAD TÊLE CYLINDRIQUE	OIL GALLERY GALERIE D'HUILE	KIT NO. TROUSSE NO.
--	---------------	---------------	-------------------------	-----------------------------------	--------------------------------	------------------------

AMC | 6 Cylinder

4.0 L (242 M,L,S)	1996-87	(4) 260-357 (2) 260-144 (1) 260-375				260-401
4.2 L (258 CID)	1988-71	(4) 260-357 (2) 260-315	(1) 260-375	(1) 260-357 (3) 260-136	(2) 262-923	260-402

AUDI | 4 Cylinder

1.6 L (1588 CC)	1993-81	(4) 261-150				
1.8 L (1780 CC)	1997-81	(4) 261-150				
2.0 L (1983 CC)	1990-81	(4) 261-150				
2.0 L (1983 CC)	1999-90	(5) 261-150				

AUDI | 5 Cylinder

2.2 L (2144CC)	1985-78	(5) 261-150 (1) 260-126 (1) 260-141		(1) 260-143		
2.2 L (2226CC)	1996-84	(5) 261-150 (1) 260-126		(1) 260-143		
2.3 L (2309CC)	1992-87	(5) 261-150				

AUDI | 6 Cylinder

2.8 L (2771CC)	1998-92	(6) 261-150				
----------------	---------	-------------	--	--	--	--

AUDI | 8 Cylinder

3.6 L (3562CC), 3.6 L (3562CC) 3.7 L (3697CC), 4.2 L (4172CC) 4.2 L (4200CC)	1998-90	A/R 261-132				
--	---------	-------------	--	--	--	--

BUICK | 4 Cylinder

1.8 L (112 CID) - O 2.0 L (122 CID) - I	1989-82	(4) 261-145 (4) 261-171		(4) 261-145	(2) 260-902 (2) 260-923 A/R 260-902	260-418
2.0 L (122 CID) - K	1989-87	(4) 261-145		(2) 260-142	(2) 260-901 (1) 260-923 A/R 260-923	
2.0 L (122 CID) - M Turbo	1987	(4) 261-145			A/R 260-902 (1) 260-923 (2) 260-901	
2.0 L (122 CID) - P	1986-83	(4) 261-171 (1) 261-145		(1) 261-145	A/R 260-902 (2) 260-901 (1) 260-923	
2.2 L (134 CID) - 4	1996-93	(4) 261-171		(1) 261-145	(2) 260-922 (2) 260-924	
2.3 L (138 CID) - D,3	1995-89	A/R 260-902		(1) 260-145 (1) 261-118	(1) 260-922 (2) 260-901 A/R 260-923	
2.3 L (138 CID) - D,3	1988	(3) 260-923	(1) 260-372	(2) 261-118 (2) 260-145	(3) 260-922 (1) 260-921	
2.4 L (146 CID) - T	1998-96	(1) 260-922		(1) 260-318 (2) 260-130		
2.5 L (151 CID)	1992-80	(1) 260-222 (3) 261-165	(1) 260-372	(1) 261-165 (1) 260-210 (4) 263-548	(2) 260-120 (1) 261-108 (1) 260-923	260-400

papeco EXPANSION PLUGS

BOUCHON D'EXPANSION

ENGINE SIZE (C.I.D.) FORMAT DE MOTEUR	YEAR ANNEE	BLOCK BLOC	CAMSHAFT ARBE A CAME	CYLINDER HEAD TÊLE CYLINDRIQUE	OIL GALLERY GALERIE D'HUILE	KIT NO. TROUSSE NO.
--	---------------	---------------	-------------------------	-----------------------------------	--------------------------------	------------------------

BUICK | 6 Cylinder

2.8 L (173 CID)	1989-80	(6) 261-145 (1) 260-136 (2) 260-922		(2) 260-315 (1) 260-902 (2) 260-901	(1) 260-902 A/R 260-922 (2) 260-923	260-407
3.0 L (181 CID)	1988-85	A/R 260-156 (4) 260-150 (4) 260-327 (4) 260-330	(1) 260-224	(4) 260-150	A/R 260-126 A/R 260-901	
3.1 L (189 CID) - J	2005-00	(1) 261-145		(2) 260-315		
3.1 L (189 CID) - M	1999-94	(1) 260-126 (4) 260-902 (1) 260-901 (1) 260-923	(1) 260-372	(4) 260-315 (1) 260-902		
3.1 L (189 CID) - T	1993 <i>Regal</i>	(6) 260-145 (2) 260-902 A/R 260-923	(1) 260-372	A/R 260-315	A/R 260-902 (2) 260-901	
	1992-89 <i>Regal</i>	(6) 260-145 (2) 260-922		A/R 260-315 (1) 260-902	A/R 260-136 A/R 260-902 A/R 260-922 (2) 260-901 A/R 260-923	
3.3 L (204 CID)	1993-89	(6) 260-327 (4) 260-330	(1) 260-224	(4) 260-150 A/R 260-156	(1) 260-923 A/R 260-922 A/R 260-902	
3.4 L (207 CID) - E	2005-02	(6) 261-145		(4) 260-315		
3.5 L (211 CID)	2005		(1) 260-372	(2) 260-315	(1) 260-126	
3.6 L (220 CID)	2005-04	(1) 261-145				
3.8 L (231 CID) 1,2,3,C,K,L	2005-88	(1) 260-224 (1) 260-315 A/R 260-901 (2) 260-922 (6) 260-327 A/R 260-330	(1) 260-224	(4) 260-150 A/R 260-156	(2) 260-120	260-406

BUICK | 8 Cylinder

5.0 L (305 CID)	1992-77	(2) 260-186 (2) 260-922	(1) 260-240 (1) 260-372 (1) 260-372		(3) 260-115 A/R 260-922 A/R 260-901 A/R 260-902	260-425
5.0 L (307 CID)	1990-80	(6) 260-177 (6) 260-327	(1) 260-240 (1) 260-372 (1) 260-372	(4) 260-318	(1) 260-138 A/R 260-923 (1) 260-924	260-413
5.7 L (350 CID) - 7	1993-92	(8) 260-186	A/R 260-372	(1) 260-923	(3) 260-115 (2) 260-902 (2) 260-922	
5.7 L (350 CID) - P	1996-94	(8) 260-186 (1) 260-922	(1) 260-372	(2) 260-922 (1) 260-923	(3) 260-115 (1) 260-901	

papeco EXPANSION PLUGS

BOUCHON D'EXPANSION

ENGINE SIZE (C.I.D.) FORMAT DE MOTEUR	YEAR ANNEE	BLOCK BLOC	CAMSHAFT ARBE A CAME	CYLINDER HEAD TÊTE CYLINDRIQUE	OIL GALLERY GALERIE D'HUILE	KIT NO. TROUSSE NO.
--	---------------	---------------	-------------------------	-----------------------------------	--------------------------------	------------------------

CADILLAC | 6 Cylinder

2.8 L (173 CID)	1988-85	(6) 261-145 (1) 260-136 (2) 260-922		(2) 260-315 (1) 260-902	(1) 260-902 A/R 260-922 (2) 260-901 (2) 260-923	
3.6 L (220 CID)	2005-04	(1) 261-145				

CADILLAC | 8 Cylinder

4.1 L (250 CID)	1988-82	(1) 261-108 A/R 260-375 (1) 260-972		(1) 260-240	(2) 260-923 (1) 260-922	
4.5 L (273 CID)	1992-88	A/R 260-375 (1) 260-921			A/R 260-128	260-415
4.6 L (281 CID)	2005-93	(1) 260-921		(2) 260-318 (1) 260-922 (1) 260-901		
4.9 L (300 CID)	1995-91	(1) 260-375 (1) 260-921			A/R 260-128	
5.0 L (305 CID)	1992-91	(2) 260-186 (2) 260-922	(1) 260-240 (1) 260-372 (1) 260-372		(3) 260-115 A/R 260-922 A/R 260-901 A/R 260-902	
5.0 L (307 CID)	1990-86	(6) 260-177 (6) 260-327	(1) 260-240 (1) 260-372 (1) 260-372	(4) 260-318	(1) 260-138 (1) 260-139 A/R 260-923 (1) 260-924	260-413
5.3 L (323 CID) - T	2005-02			(2) 260-318		
5.7 L (350 CID) - 7	1993-90	(8) 260-186	A/R 260-372	(1) 260-923	(3) 260-115 (2) 260-902 (2) 260-922	
5.7 L (350 CID) - P	1996-84	(8) 260-186 (1) 260-922	(1) 260-372	(2) 260-922 (1) 260-923	(3) 260-115 (1) 260-901	
5.7 L (350 CID) - R	2000-99	(8) 260-186				
5.7 L (350 CID) - S	2005-04	(1) 260-315		(2) 260-318	(1) 260-126	
6.0 L (364 CID) - N,U	2003-02			(2) 260-318		

CHEVROLET | 4 Cylinder

2.2 L (134 CID) - 4	2002-90	(4) 261-171		(1) 260-145 (2) 260-922	(2) 260-924	260-425
2.3 L (138 CID) - D,3	1995	A/R 260-902		(3) 260-145 (2) 261-118	(2) 260-922 A/R 260-923	
2.3 L (140 CID)	1994-90			(1) 260-145 (2) 261-118		
2.4 L (146 CID) - T	2001-96	(1) 260-922		(1) 260-318 (2) 260-130		
2.5 L (151 CID)	1992-78	(1) 260-222 (3) 261-165	(1) 260-372	(1) 261-165 (1) 260-210 (4) 263-548	(2) 260-120 (1) 261-108 (1) 260-923	260-400

CHEVROLET | 6 Cylinder

2.8 L (173 CID)	1989-80	(6) 261-145 (1) 260-136 (2) 260-922		(2) 260-315 (1) 260-902	(1) 260-902 A/R 260-922 (2) 260-901 (2) 260-923	260-407
------------------------	---------	---	--	----------------------------	--	---------

papeco EXPANSION PLUGS

BOUCHON D'EXPANSION

ENGINE SIZE (C.I.D.) FORMAT DE MOTEUR	YEAR ANNEE	BLOCK BLOC	CAMSHAFT ARBE A CAME	CYLINDER HEAD TÊLE CYLINDRIQUE	OIL GALLERY GALERIE D'HUILE	KIT NO. TROUSSE NO.
--	---------------	---------------	-------------------------	-----------------------------------	--------------------------------	------------------------

CHEVROLET | 6 Cylinder (Cont'd)

3.1 L (189 CID) - D	1995-90	(6) 261-145	(1) 260-372		(2) 260-921	
	Lumina	(3) 260-922			(3) 260-923	
3.1 L (189 CID) - J	2003-00	(1) 261-145		(2) 260-315		
	Lumina Malibu					
3.1 L (189 CID) - M	1999-94	(1) 260-126	(1) 260-372	(4) 260-315		
		(4) 260-902		(1) 260-902		
		(1) 260-901				
		(1) 260-923				
3.1 L (189 CID) - T	1994-93	(6) 260-145	(1) 260-372	(4) 260-315	A/R260-902	
		(1) 260-123			(2) 260-901	
		(2) 260-922				
3.4 L (207 CID) - E,F	2005-96	(6) 261-145		(4) 260-315	(2) 260-923	
		(2) 260-922		(1) 260-902	A/R 260-922 (1) 260-902 (4) 260-901	
3.4 L (207 CID) - S	1995-93	(6) 261-145	(1) 260-372			
		(1) 260-922				
		(5) 260-902				
		(3) 260-901 (2) 260-923				
3.4 L (207 CID) - X	1997-91	(6) 261-145	(1) 260-372	(2) 261-145	(2) 260-902	
		(2) 260-922		(2) 260-902	(2) 260-901	
3.8 L (231 CID) - I,K,L	2005-88	(1) 260-224	(1) 260-224	(4) 260-150	(2) 260-120	260-410
		(1) 260-315		A/R 260-156		
		(3) 260-922				
		A/R260-901				
		A/R260-330 (6) 260-327				
4.3 L (262 CID)	1993-91	(8) 261-186	(1) 260-372	(1) 260-922	(1) 260-126	260-413
		(1) 260-922		A/R260-923	(1) 260-125	
	1990-85	(6) 260-186	(1) 260-240 (1) 260-372		(1) 260-126 (5) 260-922	

CHEVROLET | 8 Cylinder

4.3 L (265 CID)	1996-94	(2) 260-186				260-425
5.0 L (305 CID)	1993-76	(2) 260-186	(1) 260-240		(3) 260-115	260-425
		(2) 260-922	(1) 260-372		A/R 260-922	
			(1) 260-372		A/R 260-901 A/R 260-902	
5.0 L (307 CID)	1990-86	(6) 260-177	(1) 260-240	(4) 260-318	(1) 260-138	260-425
		(6) 260-327	(1) 260-372 (1) 260-372		(1) 260-139 A/R260-923 (1) 260-924	
5.7 L (350 CID) - 5	1996	(8) 260-186 (1) 260-113	A/R 260-372		(3) 260-115 (1) 260-113 (2) 260-121	260-425
5.7 L (350 CID) - 6	1988-80	(2) 260-186	(1) 260-372 (1) 260-372 (1) 260-240		(3) 260-115 (5) 260-922	

papeco EXPANSION PLUGS

BOUCHON D'EXPANSION

ENGINE SIZE (C.I.D.) FORMAT DE MOTEUR	YEAR ANNEE	BLOCK BLOC	CAMSHAFT ARBE A CAME	CYLINDER HEAD TÊLE CYLINDRIQUE	OIL GALLERY GALERIE D'HUILE	KIT NO. TROUSSE NO.
--	---------------	---------------	-------------------------	-----------------------------------	--------------------------------	------------------------

CHEVROLET | 8 Cylinder (Cont'd)

5.7 L (350 CID) - 7	1993-89	(8) 260-186 (1) 260-113	A/R 260-372	(1) 260-923	(3) 260-115 (1) 260-113 (1) 260-121 (2) 260-922 (2) 260-902	
5.7 L (350 CID) - 8	1992-80	(2) 260-186 (2) 261-165	(1) 260-372		(3) 260-115 (1) 260-113 (2) 260-121 (5) 260-922	260-425
5.7 L (350 CID) - G	2004-97	(1) 260-315		(2) 260-318	(1) 260-126	
5.7 L (350 CID) - J	1995-89			(2) 261-138	(1) 260-141	
5.7 L (350 CID) - P	1997-92	(8) 260-186 (1) 260-113 (1) 260-922	(2) 260-372	(2) 260-922 (1) 260-923	(3) 260-115 (2) 260-121 (1) 260-113 (1) 260-901	260-425
5.7 L (350 CID) - S	2004-01			(2) 260-318		
6.0 L (364 CID)	2005			(2) 260-318		

CHEVROLET/GMC TRUCK | 4 Cylinder

2.2 L (134 CID) - 4,5	2003-94	(4) 261-171		(1) 261-145	(2) 260-922 (2) 260-924	
2.5 L (151 CID)	1993-85	(1) 260-222 (3) 261-145	(1) 260-372	(1) 261-165 (1) 260-210 (4) 263-548	(2) 260-120 (1) 261-108 (1) 260-923	

CHEVROLET/GMC TRUCK | 6 Cylinder

2.8 L (173 CID)	1993-82	(6) 261-145 (1) 260-136 (2) 260-922		(2) 260-315 (1) 260-902	(4) 260-901 (2) 260-923 A/R 260-922 (1) 260-902	260-407
4.3 L (262 CID)	2005-94	(8) 260-186 (8) 260-165 (3) 260-902	(1) 260-240 (1) 260-372	(1) 260-972 A/R 260-923	(3) 260-115 (1) 260-125 (2) 260-126	260-412
	1993-91	(8) 260-186 (1) 260-922	(1) 260-372	(1) 260-922 A/R 260-923	(1) 260-125 (1) 260-113	
	1990-86	(6) 260-186 (1) 260-372	(1) 260-240	(1) 260-125	(3) 260-115 (1) 260-126 (5) 260-922	260-413
4.8 L (292 CID)	1989-63	(1) 260-234 (3) 260-186	(3) 260-240 (1) 260-372 (1) 260-372	(3) 260-142	(3) 260-120 (1) 260-923	260-415

CHEVROLET/GMC TRUCK | 8 Cylinder

4.8 L (294 CID) - V	2005-99			(1) 260-318	(1) 260-126	
5.0 L (305 CID)	2002-76	(2) 260-922	(1) 260-372 (1) 260-372		(3) 260-115 (6) 260-922 A/R 260-902 A/R 260-901	260-425
<i>Note: 2002-01 Block (8) 261-165 2000-76 Block (2) 261-186</i>						
5.7 L (323 CID)-B,M,P,T,Z	2005-99			(2) 260-318	(1) 260-126	
5.7 L (350 CID) - K	1996-73	(8) 260-186	(1) 260-240 (1) 260-372 (1) 260-372		(3) 260-115 (5) 260-922	260-425

papeco EXPANSION PLUGS

BOUCHON D'EXPANSION

ENGINE SIZE (C.I.D.) FORMAT DE MOTEUR	YEAR ANNEE	BLOCK BLOC	CAMSHAFT ARBE A CAME	CYLINDER HEAD TÊLE CYLINDRIQUE	OIL GALLERY GALERIE D'HUILE	KIT NO. TROUSSE NO.
--	---------------	---------------	-------------------------	-----------------------------------	--------------------------------	------------------------

CHEVROLET/GM TRUCK 8 Cylinder (Cont'd)							
5.7 L (350 CID) - M	1988-79	(8) 260-186	(1) 260-240		(3) 260-115	260-425	
			(1) 260-372 (1) 260-372		(5) 260-922		
5.7 L (350 CID) - P	1988	(8) 260-186 (1) 260-113 (1) 260-922	(1) 260-372	(1) 260-922 (1) 260-923	(3) 260-115 (2) 260-121 (1) 260-113 (1) 260-901	260-425	
5.7 L (350 CID) - R	2002-01	AR261-165					
	2000-96	(8) 260-186					
6.0 L (364 CID) - U,N	2005-01			(2) 260-318	(1) 260-126		
6.0 L (366 CID)	1998-83	(11) 260-204 (1) 260-186	(1) 260-385 (1) 260-385		(7) 260-922 AR260-901	260-426	
6.2 L (379 CID)	1993-82 <i>Diesel</i>	(6) 261-165 (2) 260-923	(1) 260-385	(8) 260-303 (1) 260-136 AR260-923	AR260-117 AR260-126	260-421	
6.5 L (395 CID)	2002-92 <i>Diesel</i>	(6) 261-165 AR260-922	(1) 260-385	(4) 260-303			
6.6 L (400 CID) - 1,2	2005-01			(1) 261-118			
7.0 L (427 CID)	1998-83	(11) 260-204 (1) 260-186	(1) 260-385 (1) 260-385		(7) 260-922 AR260-901		
7.4 L (454 CID)	2000-70	(11) 260-204 (1) 260-186	(1) 260-385 (1) 260-385		(7) 260-922	260-426	
8.1 L (496 CID) - G,E	2005-01		(1) 260-385	(2) 260-318			
CHRYSLER 4 Cylinder							
2.0 L (122 CID)	2000-95	(4) 260-324 (1) 260-311		(2) 260-318 (2) 260-303			
	<i>Sebring</i>						
2.2 l (135 CID)	1990-82	(5) 260-186 (1) 260-193 (1) 260-922		(2) 260-318 (1) 260-186 (2) 260-128 AR260-923	(4) 260-902 (4) 260-128	260-434	
2.4 L (148 CID)	2005-95	(2) 260-321 (2) 260-189 (1) 260-311					
2.5 L (153 CID)	1993-86	(5) 260-186		AR260-923 (2) 260-318 (1) 260-923		260-434	
CHRYSLER 6 Cylinder							
2.5 L (152 CID)	2000-95	(1) 260-922 (5) 260-315 (2) 261-146 (1) 261-165 (2) 260-922 (3) 260-923		AR260-923 (2) 260-318 (1) 260-923			
2.7 L (2700 CC)	2004-98 <i>Concorde</i>	(1) 260-315 (8) 260-189		(2) 260-318			
3.0 L (181 CID)	2005-00	(5) 260-315 AR261-165 (4) 261-146				260-430	

napco EXPANSION PLUGS

BOUCHON D'EXPANSION

ENGINE SIZE (C.I.D.) FORMAT DE MOTEUR	YEAR ANNEE	BLOCK BLOC	CAMSHAFT ARBE A CAME	CYLINDER HEAD TÊLE CYLINDRIQUE	OIL GALLERY GALERIE D'HUILE	KIT NO. TROUSSE NO.
--	---------------	---------------	-------------------------	-----------------------------------	--------------------------------	------------------------

CHRYSLER | 6 Cylinder (Cont'd)

3.0 L (181 CID)	1995-88	(5) 260-315		(2) 261-146		
		(2) 261-146		(2) 260-922		
3.0 L (2972 CC)	1991-90TC	(1) 261-165		(1) 260-923		
		(1) 260-923				
		(2) 260-922				
		(2) 260-921				
		(5) 260-315		(4) 260-315		
		(2) 261-146		(2) 261-146		
3.2 L (3200 CC)	2001-98Concorde	(1) 261-165		(6) 260-920		
		(2) 260-922		A/R 260-921		
		(1) 260-921		(2) 260-922		
		(3) 260-923				
3.3 L (201 CID)	2005-94	(8) 260-189	(1) 260-388	(4) 260-318	(5) 260-311	260-436
		(1) 260-311		(2) 260-126	(4) 260-311 Rocker Arm	
3.3 L (201 CID)	1993-90	(8) 260-189	(1) 260-126	(4) 260-318	(5) 260-311	260-432
		(8) 260-186		(2) 260-126	(4) 260-311 Rocker Arm	
3.5 L (215 CID)	1997-93	(8) 260-189		(2) 260-318	(4) 260-303	260-432
		(5) 260-311			Rocker Arm	
		(8) 260-126				
3.5 L (215 CID) - G	2005-99	A/R 260-128		(4) 260-318	(3) 260-311	
3.8 L (230 CID)	2005-94	(1) 260-128	(1) 260-388	(4) 260-318	(5) 260-311	260-432
		(8) 260-189			(2) 260-126	
3.8 L (230 CID)	1993-91	(8) 260-189			(4) 260-311	
		(8) 260-318	(1) 260-388	(4) 260-318	(5) 260-311	
		(8) 260-189			(2) 260-126	
					(4) 260-311 Rocker Arm	

DODGE | 4 Cylinder

1.5 L (1468 CC)	1994-85 Colt,Vista	(8) 261-146		(2) 261-146		
		(1) 260-922		(4) 260-920		
		(1) 260-923		(2) 260-922		
1.6 L (1597 CC)	1990-89 Colt Turbo	(2) 260-921		(2) 260-921		
		(7) 261-146				
		(1) 260-920				
1.8 L (1834 CC)	1994-89 Colt,Vista	(1) 260-923				
		(9) 260-146		(1) 260-146		
2.0 L (122 CID)	2005-95	(2) 260-922		(1) 260-922		
		(1) 260-311		(2) 260-318		
2.0 L (2000 CC)	1991-84 Vista	(4) 260-324		(6) 260-303		
		(9) 260-146		(1) 260-146		
		(9) 261-161		(1) 260-161		
		(2) 260-920		(1) 260-922		
		(1) 260-921		(9) 260-921		
(1) 260-923						

papeo EXPANSION PLUGS

BOUCHON D'EXPANSION

ENGINE SIZE (C.I.D.) FORMAT DE MOTEUR	YEAR ANNEE	BLOCK BLOC	CAMSHAFT ARBE A CAME	CYLINDER HEAD TÊLE CYLINDRIQUE	OIL GALLERY GALERIE D'HUILE	KIT NO. TROUSSE NO.
--	---------------	---------------	-------------------------	-----------------------------------	--------------------------------	------------------------

DODGE 4 Cylinder (Cont'd)						
2.2 L (135 CID)	1994-81	(5) 260-186 (1) 260-193 (1) 260-922		(2) 260-318 (1) 260-186 (2) 260-128 A/R260-923	(2) 260-311 (2) 260-128 (2) 260-311 (2) 260-128	260-434
2.4 L (148 CID)	2005-95	(2) 260-321 (2) 260-189 (1) 260-311		(2) 260-318		
2.5 L (153 CID)	1995	(5) 260-186 (1) 260-193 (1) 260-922		(2) 260-318 (2) 260-128 A/R260-923	(4) 260-311 (4) 260-128	260-434
2.5 L (153 CID)	1994-93 <i>Spirit</i>	(3) 260-207 (5) 260-186 (1) 260-246 (1) 260-193 (1) 260-922		(2) 260-318 (1) 260-357 (4) 260-136 (2) 260-128 A/R260-923	(4) 260-311 (4) 260-128	
2.5 L (153 CID)	1994-93 <i>Exc: Spirit</i>	(5) 260-186 (1) 260-193		(2) 260-318 (2) 260-128	(4) 260-311 (4) 260-128	
	1992-86	(1) 260-922		A/R260-923	(4) 260-128	
DODGE 6 Cylinder						
2.5 L (152 CID)	2000-95	(5) 260-315 (2) 261-146 (1) 261-165 (2) 260-922 (3) 260-923		(2) 260-318 (1) 260-923		
2.7 L (2700 CC)	2005-98 <i>Intrepid</i>	(8) 260-189 (1) 260-311		(2) 260-318		
3.0 L (181 CID)	2005-87	(5) 260-315 (2) 261-146 (1) 261-165 (2) 260-922 (2) 260-921 (1) 260-923		(2) 260-146 (2) 260-920 (2) 260-922	(1) 260-923 <i>oil pump pipe</i>	260-430
3.0 L (182 CID)	1992-90 <i>Monaco</i>	(2) 260-315 (2) 261-108		(6) 260-146		
3.0 L (2972 CC)	1996-91 <i>Stealth</i>	(1) 261-165 (5) 260-315 (2) 261-146 (3) 260-923 (1) 260-921 (2) 260-922		(4) 260-315 (2) 261-146 (6) 260-920 A/R260-921 (2) 260-922		
3.2 L (3200 CC)	2001-98 <i>Intrepid</i>	(8) 260-189		(2) 260-318		
3.3 L (201 CID)	2005-94	(2) 260-128 (8) 260-189	(1) 260-388	(4) 260-318	(5) 260-311 (2) 260-126 (4) 260-311 <i>Rocker Arm Shaft</i>	260-436
	1993-90	(8) 260-189 (8) 260-186	(1) 260-388	(4) 260-318	(5) 260-311 (2) 260-126 (4) 260-311	260-432
3.5 L (215 CID)	1997-93	(8) 260-189 (5) 260-311 (8) 260-126		(2) 260-318	(4) 260-303 <i>Rocker Arm Shaft</i>	260-432

papeo EXPANSION PLUGS

BOUCHON D'EXPANSION

ENGINE SIZE (C.I.D.) FORMAT DE MOTEUR	YEAR ANNEE	BLOCK BLOC	CAMSHAFT ARBE A CAME	CYLINDER HEAD TÊLE CYLINDRIQUE	OIL GALLERY GALERIE D'HUILE	KIT NO. TROUSSE NO.
--	---------------	---------------	-------------------------	-----------------------------------	--------------------------------	------------------------

DODGE | 6 Cylinder (Cont'd)

3.5 L (215 CID) - G	2005-99	A/R260-189		(4) 260-318	(3) 260-311	
		A/R260-128				
3.8 L (230 CID)	2005-94	(8) 260-189		(4) 260-318	(5) 260-311	260-432
		(1) 260-128			(2) 260-126	

DODGE | 8 Cylinder

5.2 L (318 CID)	1989-85	(9) 260-186	(1) 260-213	(4) 260-318	(4) 260-311	
		A/R260-193			<i>Rocker Arm Shaft</i>	
		(1) 260-318			A/R 260-923	
		(1) 260-924			(3) 260-924	
		(2) 260-922			(2) 260-922	
				(4) 260-311	<i>Rocker Arm Shaft</i>	

DODGE | 10 Cylinder Viper (See Dodge/Plymouth Truck)

DODGE/PLYMOUTH TRUCK | 4 Cylinder

2.0 L (122 CID)	1989-93	(9) 261-146		(1) 261-161			
		(9) 261-161		(1) 260-920			
		(2) 260-920		(1) 260-922			
		(1) 260-923					
2.2 L (135 CID)	1988-87	(5) 260-186		(2) 260-318	(4) 260-311	260-434	
		(1) 260-193		(2) 260-321	(4) 260-128		
		(1) 260-922		A/R260-923			
2.4 L (143 CID)	1993-90	(9) 261-146		(1) 261-161			
		(2) 260-920		(1) 260-922			
		(1) 260-923					
2.5 L (153 CID)	2002-96	(3) 260-207		(1) 260-357			
		(1) 260-246		(4) 260-136			
	1995-94	(5) 260-189		(2) 260-318	(4) 260-311		
					(4) 260-128		
	1993-90	(5) 260-186		(2) 260-318	(4) 260-311		260-434
		(1) 260-922		A/R260-321	(4) 260-318		
			A/R260-923				
2.6 L (156 CID)	1989-87	(4) 261-132		(1) 261-161			
		(3) 261-161		(1) 260-920			
2.6 L (156 CID)	1989-87	(3) 261-185		(1) 260-922			
		(1) 260-922					
		(1) 260-921					
		(1) 260-923					

DODGE/PLYMOUTH TRUCK | 6 Cylinder

3.0 L (2972 CC)	1991-89	(5) 260-315		(2) 261-146		
		(2) 261-146		(2) 260-920		
		(1) 261-165		(2) 260-922		
		(2) 260-922				
		(1) 260-921				
		(3) 260-923				
3.7 L (225 CID)	1987-92	(5) 260-186	(1) 260-375	(2) 260-311	(2) 260-923	
					(4) 260-311	
					<i>Rocker Arm Shaft</i>	
3.9 L (239 CID)	2003-94	A/R260-189		(4) 260-318		
		(1) 260-318				
	1993-90	(1) 260-318		(4) 260-318		
		(7) 260-186				

papeo EXPANSION PLUGS

BOUCHON D'EXPANSION

ENGINE SIZE (C.I.D.) FORMAT DE MOTEUR	YEAR ANNEE	BLOCK BLOC	CAMSHAFT ARBE A CAME	CYLINDER HEAD TÊLE CYLINDRIQUE	OIL GALLERY GALERIE D'HUILE	KIT NO. TROUSSE NO.
--	---------------	---------------	-------------------------	-----------------------------------	--------------------------------	------------------------

DODGE/PLYMOUTH TRUCK 8 Cylinder						
4.7 L (285 CID) - N	2005-00	(10) 260-324 (1) 260-128		(2) 260-318 (1) 260-303		
5.2 L (318 CID)	2003-92	(1) 260-318 (9) 260-189	(1) 260-213 (1) 260-026	(4) 260-318	(1) 261-108 (1) 260-118	
	1991-84	(1) 260-318 (9) 260-186 (1) 260-924 (2) 260-922	(1) 260-066 (1) 260-213	(4) 260-318	A/R260-923 (3) 260-924 (2) 260-922 (4) 260-311 <i>Rocker Arm Shaft</i>	
5.9 L (360 CID)	2005-97 Diesel	(6) 260-105 (2) 260-318 (4) 260-315 (3) 260-128		(14) 260-315 (7) 260-105 (5) 260-133		
	1996-98	(3) 260-128 (1) 260-136 (2) 260-105 (1) 260-318 (4) 260-315		(12) 260-103 (5) 260-133 (5) 260-315 (4) 260-921 (5) 260-924		
5.9 L (360 CID)	2003-93	(1) 260-318 (9) 260-189	(1) 260-213 (1) 260-066	(4) 260-318	(1) 261-108 (1) 261-118	
	1992-84	(1) 260-318 (9) 260-186 (1) 260-924 (2) 260-922	(1) 260-213 (1) 260-066	(4) 260-318	A/R260-923 (2) 260-922 (3) 260-924 (4) 260-311 <i>Rocker Arm Shaft</i>	
DODGE/PLYMOUTH TRUCK 10 Cylinder						
8.0 L (488 CID)	2003-94	A/R260-315 A/R260-189 (1) 260-921	(1) 260-318 (1) 260-315			
EAGLE 4 Cylinder						
1.5 L (1468 CC)	1996-89 <i>Summit</i>	(8) 261-146 (1) 260-922 (1) 260-923		(2) 261-146 (2) 260-921 (4) 260-920 (2) 260-922		
1.6 L (1597 CC)	1990-89 <i>Summit</i>	(7) 261-146 (1) 260-920 (1) 260-923		(1) 261-161 (2) 260-921		
1.8 L (1754 CC)	1994-90 <i>Talon</i>	(7) 261-146 (1) 260-921 (1) 260-923 (1) 260-920		(1) 261-146 (1) 260-920 (2) 260-922		
1.8 L (1834 CC)	1996-92 <i>Summit</i>	(9) 261-146 (2) 260-922		(1) 261-146 (1) 260-922		
2.0 L (122 CID)	1998-95 <i>Talon</i> <i>w/o turbo</i>	(1) 260-311 (4) 260-324		(6) 260-303 (2) 260-318		

EXPANSION PLUGS

BOUCHON D'EXPANSION

ENGINE SIZE (C.I.D.) FORMAT DE MOTEUR	YEAR ANNEE	BLOCK BLOC	CAMSHAFT ARBE A CAME	CYLINDER HEAD TELE CYLINDRIQUE	OIL GALLERY GALERIE D'HUILE	KIT NO. TROUSSE NO.
--	---------------	---------------	-------------------------	-----------------------------------	--------------------------------	------------------------

EAGLE | 4 Cylinder (Cont'd)

2.0 L (122 CID)	1998-90 <i>Talon</i> <i>w/turbo</i>	(7) 261-146 (2) 260-920		(1) 261-146 (2) 261-161		
		(1) 260-923		(9) 260-921		
	1994-90 <i>Talon</i> <i>w/o turbo</i>	(9) 261-146 (2) 260-920		(1) 261-146 (9) 260-921		
		(1) 260-923				
2.4 L (2351 CC)	1996-92 <i>Summit</i>	(7) 261-146		(2) 261-146		
		(2) 261-161		(9) 260-921		
		(1) 260-923				
		(2) 260-920				
		(1) 260-924				

EAGLE | 6 Cylinder

3.0 L (182 CID)	1992-88 <i>Premier</i>	(2) 260-315 (2) 261-108		(6) 260-146		
3.3 L (201 CID)	1997-93 <i>Vision</i>	(8) 260-189	(1) 260-388	(2) 260-318	(5) 260-311 (2) 260-126 (4) 260-311 <i>Rocker Arm Shaft</i>	
3.5 L (215 CID)	1997-93 <i>Vision</i>	(8) 260-189		(2) 260-318	(4) 260-303 <i>Rocker Arm Shaft</i>	
		(5) 260-311				
		(8) 260-126				

FORD | 4 Cylinder

1.3 L (1295 CC)	1997-94 <i>Aspire</i>	(4) 260-147 (4) 260-324		(1) 260-147		
	1993-88 <i>Festiva</i>	(2) 261-114 (6) 261-138 (3) 261-146		(6) 261-138 A/R260-108		
1.8 L (110 CID)	1996-91 <i>Escort</i>	(2) 261-114 (4) 261-138 (4) 261-146		A/R261-118		
1.9 L (116 CID)	1996-91 <i>Escort</i>	(4) 260-324	(1) 260-136	(2) 260-327		
		(1) 260-249		A/R261-114		
		(1) 261-114		A/R261-158		
		(3) 260-922		(3) 260-923		
		(3) 260-921				
2.0 L (122 CID)	2000-95 <i>Contour</i>	(1) 260-249		(1) 260-171	(1) 260-318	
		(4) 260-324		(2) 260-923	<i>Intake Manifold</i>	
		(4) 260-249		(2) 260-327		
		(4) 261-114		(4) 261-114		
		(1) 260-249		A/R261-158		
	1997-93 <i>Probe</i>	(9) 261-138		(1) 261-138		
		(1) 261-146		(1) 260-923		
		(2) 261-114		(2) 260-128		
2.0 L (122 CID) - 3	2005-00 <i>Escort, Focus</i>	(4) 260-324		(1) 260-171		
		(1) 260-249		(2) 260-923		
2.0 L (122 CID) - P	2005-00 <i>Escort, Focus</i>	(4) 260-324		(2) 260-327	(1) 260-318	
		(4) 261-114		(4) 261-114	<i>Intake Manifold</i>	
		(1) 260-249		A/R261-158		

papco EXPANSION PLUGS

BOUCHON D'EXPANSION

ENGINE SIZE (C.I.D.) FORMAT DE MOTEUR	YEAR ANNEE	BLOCK BLOC	CAMSHAFT ARBE A CAME	CYLINDER HEAD TÊLE CYLINDRIQUE	OIL GALLERY GALERIE D'HUILE	KIT NO. TROUSSE NO.
--	---------------	---------------	-------------------------	-----------------------------------	--------------------------------	------------------------

FORD 4 Cylinder (Cont'd)						
2.2 L (133 CID)	1992-89	(1) 261-161				
	<i>Probe</i>	(1) 261-146 (2) 261-114 (2) 260-315 A/R261-138				
2.3 L (140 CID)	1994-84	(8) 260-207		(1) 260-252	(3) 260-923	260-446
	<i>Tempo</i>	(1) 260-249 A/R260-922 (2) 260-923 (5) 260-926			(4) 260-327	
	1994-84	A/R260-922		(3) 260-922	(4) 260-124	
	<i>exc: Tempo</i>	A/R260-923 (1) 260-365 (1) 260-366 (1) 260-243 (4) 260-327 (4) 260-330			<i>Timing Hole</i>	
2.5 L (153 CID)	1990-86	(4) 260-207		(1) 260-252	(3) 260-923	
		(1) 260-249 A/R260-922 (4) 260-207 (5) 260-926			(1) 260-327	
FORD 6 Cylinder						
2.5 L (152 CID)	1997-93				(4) 261-161	
	<i>Probe</i>				(2) 260-128	
3.0 L (182 CID)	2005-86	(4) 260-922	(1) 260-252	(5) 260-318	(6) 260-922	
	<i>exc: SHO Eng.</i>	(2) 260-923 (5) 260-327 A/R260-336 A/R260-183		(2) 260-127	A/R260-923 (1) 260-124 <i>Timing Hole</i>	
	1995-86	(6) 261-146		(6) 260-901	(2) 260-922	260-448
	<i>exc: SHO Eng.</i>	(6) 261-161 (2) 260-922				
3.2 L (195 CID)	1995-93	(6) 261-146 (6) 261-161 (2) 260-922		(6) 260-921		
3.8 L (232 CID)	2004-95	A/R260-327	A/R260-336	(2) 260-189		260-442
		A/R260-189 A/R260-183 (4) 260-922 A/R 260-923				
	1994-82	A/R 260-327	A/R260-336	(2) 260-189		260-442
		A/R 260-183 (4) 260-922 A/R 260-923				
4.0 L (245 CID)	2005			A/R260-183		
FORD 8 Cylinder						
3.4 L (207 CID)	1999-96	(2) 260-327				
	1999	(2) 260-327				

napco[®] EXPANSION PLUGS

BOUCHON D'EXPANSION

ENGINE SIZE (C.I.D.) FORMAT DE MOTEUR	YEAR ANNEE	BLOCK BLOC	CAMSHAFT ARBE A CAME	CYLINDER HEAD TÊTE CYLINDRIQUE	OIL GALLERY GALERIE D'HUILE	KIT NO. TROUSSE NO.
--	---------------	---------------	-------------------------	-----------------------------------	--------------------------------	------------------------

FORD | 8 Cylinder (Cont'd)

4.6 L (281 CID)	2005-96 DOHC	(2) 260-308 (1) 260-130 (2) 260-923 A/R260-327		(2) 260-318 A/R260-305 (6) 260-923		260-457
	2005-96 SOHC	(2) 260-308 (2) 260-923 A/R260-327		A/R260-305 (6) 260-923		
	1995-92	(2) 260-923 A/R260-327		A/R260-305 (6) 260-923		
5.0 L (302 CID)	1995-68	A/R260-923 (1) 260-130 A/R260-327 A/R260-330	(1) 260-243 (1) 260-249 (7) 260-926		(3) 260-114 (5) 260-922 (1) 260-130 (1) 260-129	260-451
5.8 L (351 W)	1991-68	A/R260-923 (1) 260-130 A/R260-327 A/R260-183	(1) 260-243 (1) 260-249	(1) 260-926	(3) 260-114 A/R260-922 (1) 260-130 (1) 260-129	260-451

FORD TRUCK | 4 Cylinder

2.0 L (122 CID)	2001-01	(1) 260-249 (4) 260-324		(1) 260-171		
2.3 L (140 CID)	1997-95	(4) 260-327 (1) 260-305 (1) 260-365 (1) 260-313 (1) 260-366 (1) 260-923 (1) 260-327	(4) 260-183	(3) 260-922	(4) 260-124 Timing Hole	260-446
	1994-91	(4) 260-327 A/R260-922 A/R260-923 (1) 260-365 (1) 260-366 (1) 260-243 (4) 260-327 (4) 260-183		(3) 260-922	(4) 260-124 Timing Hole	260-446
2.5 L (150 CID)	2001-98 Ranger	(1) 260-305 (1) 260-315 (1) 260-130 (6) 260-327				

FORD TRUCK | 6 Cylinder

2.9 L (177 CID)	1992-86	(16) 260-921 A/R260-327 A/R260-189	A/R260-366 (1) 260-231	(4) 260-926	(1) 260-922	
3.0 L (182 CID)	2005-86	(4) 260-922 (2) 260-923 (5) 260-327 A/R260-336 A/R260-183	(1) 260-252	(5) 260-318 (2) 260-127	(6) 260-922 A/R 260-923 A/R 260-128 (1) 260-171 Timing Hole	260-448
3.8 L (232 CID)	2003-95	A/R260-327 A/R260-189 A/R160-183 (4) 260-922 A/R 260-923	A/R260-336	(2) 260-189	(3) 260-923	260-442

papeo EXPANSION PLUGS

BOUCHON D'EXPANSION

ENGINE SIZE (C.I.D.) FORMAT DE MOTEUR	YEAR ANNEE	BLOCK BLOC	CAMSHAFT ARBE A CAME	CYLINDER HEAD TÊLE CYLINDRIQUE	OIL GALLERY GALERIE D'HUILE	KIT NO. TROUSSE NO.
--	---------------	---------------	-------------------------	-----------------------------------	--------------------------------	------------------------

FORD TRUCK | 6 Cylinder (Cont'd)

4.0 L (245 CID)	2005-97	(4) 260-922 A/R260-183 A/R260-327		(4) 260-183		
	1996-90	(4) 260-921 A/R260-327		(4) 260-183		
4.2 L (256 CID)	2005-97	A/R260-189 (8) 260-327				
4.9 L (300 CID)	1996-65	A/R260-189 (1) 260-114 (1) 260-365 (1) 260-366 (1) 260-105 (1) 260-243 A/R260-922 A/R260-336	(1) 260-249 (1) 260-252	(1) 260-365 (1) 260-366 A/R260-189 (1) 260-243 (1) 260-926	(1) 260-100 (6) 260-305 A/R260-922 (4) 260-923 (1) 260-129	260-450

FORD TRUCK | 8 Cylinder

4.6 L (281 CID)	2005-97	(2) 260-308 (2) 260-923 A/R260-327		A/R260-305 (6) 260-923		260-457
5.0 L (302 CID)	2001-68	A/R260-923 (1) 260-130 A/R260-327 A/R260-183	(1) 260-243 (1) 260-249	(7) 260-926	(3) 260-114 A/R260-922 (1) 260-130 (1) 260-129	260-451
5.4 L (330 CID)	2005-97	(2) 260-308 (6) 260-327			(2) 260-305	
5.8 L (351 W)	1997-95	A/R260-923 (1) 260-177 A/R260-327 A/R260-183	(1) 260-243 (1) 260-249	(7) 260-926	(3) 260-114 A/R260-922 (1) 260-130	260-451
6.6 L (401 CID)	1991-87	(5) 260-183		(1) 260-345		260-451
7.3 L (444 CID)	1994-88 <i>Diesel</i>	(8) 260-156		(4) 260-324	(4) 260-922	
7.5 L (460 CID)	1997-73	(6) 260-327 (6) 260-183	(1) 260-260	(1) 260-327 (2) 260-127	A/R260-305 (4) 260-922 (7) 260-923	260-454
7.8 L (427 CID)	<i>F10 Diesel</i>	(5) 260-174 (1) 261-111 (1) 260-345 (1) 260-924 (3) 260-922 (1) 260-926		(6) 260-150 A/R261-138		260-455

FORD TRUCK | 10 Cylinder

6.8 L (415 CID)	2005-97	(2) 260-308		(2) 260-305		
------------------------	---------	-------------	--	-------------	--	--

GEO | 3 Cylinder

1.0 L (61 CID)	2000-89 <i>Metro</i>	(2) 260-922 (1) 260-921 A/R260-923		(1) 260-315 (3) 261-118	A/R260-923	
-----------------------	-------------------------	--	--	----------------------------	------------	--

GEO | 4 Cylinder

1.3 L (79 CID)	1994-92	(2) 260-922 (1) 260-921 A/R260-923		(1) 260-105 (3) 261-118		
-----------------------	---------	--	--	----------------------------	--	--

papeco EXPANSION PLUGS

BOUCHON D'EXPANSION

ENGINE SIZE (C.I.D.) FORMAT DE MOTEUR	YEAR ANNEE	BLOCK BLOC	CAMSHAFT ARBE A CAME	CYLINDER HEAD TÊLE CYLINDRIQUE	OIL GALLERY GALERIE D'HUILE	KIT NO. TROUSSE NO.
--	---------------	---------------	-------------------------	-----------------------------------	--------------------------------	------------------------

GEO 4 Cylinder (Cont'd)						
1.6 L (1588 CC)	1997-89	(4) 261-146		A/R 260-315	(2) 260-923	
	<i>Prism, Storm</i>	(1) 261-161		(3) 261-132		
1.8 L (1788 CC)	1997-92	(4) 261-146		A/R 260-315	(2) 260-923	
	<i>Prism, Storm</i>	(1) 261-161		(3) 261-132		
HONDA 4 Cylinder						
2.6 L (2559 CC)	1996-94	(6) 260-392		(2) 260-144		
	<i>Passport</i>			(1) 261-161		
HONDA 6 Cylinder						
3.2 L (3165 CC)	1997-94			(2) 260-153		
	<i>Passport</i>					
HUMMER 8 Cylinder						
6.0 L (364 CID) - U	2005-03			(2) 260-318		
HYUNDAI 4 Cylinder						
1.5 L (1468 CC)	1994-87	(8) 261-146		(1) 261-146		
		(1) 260-922		(1) 260-920		
		(1) 260-923		(1) 260-921		
1.5 L (1495 CC)	2002-93			(1) 260-922		
				(1) 260-315		
				A/R 261-146		
1.5 L (1495 CC) - G,4,E,K	1998-93	(8) 261-146				
1.6 L (1596 CC)	1995-92	(9) 261-146		(2) 260-147		
		(2) 260-920		(9) 260-921		
		(1) 260-923				
1.6 L (1600 CC)	2003-01	(2) 260-920		(3) 260-147		
1.8 L (1795 CC)	1999-96	(3) 260-923		(1) 260-315		
		(9) 261-146		(2) 260-147		
				(1) 261-114		
				(8) 260-920		
				(4) 260-921		
				(3) 261-121		
1.8 L (1796 CC)	1999-98			(1) 260-315		
				(2) 260-147		
				(1) 261-114		
1.8 L (1836 CC)	1995-93	(9) 261-146		(2) 260-147		
		(2) 260-920		(1) 261-146		
		(3) 260-923		(9) 260-921		
2.0 L (1975 CC)	1998-97	(9) 261-146				
	<i>Tiburon</i>					
2.0 L (1997 CC)	1997			(2) 260-147		
	<i>Tiburon</i>					
2.0 L (1997 CC)	2003-99			(1) 261-114		
				(2) 260-147		
				(1) 260-315		
2.0 L (1997 CC) - G4CP	1998-95	(9) 261-146		(1) 261-146		
		(2) 260-920		(9) 260-921		
		(1) 260-923				
2.4 L (2351 CC)	2003-99			(1) 261-146		

papeo EXPANSION PLUGS

BOUCHON D'EXPANSION

ENGINE SIZE (C.I.D.) FORMAT DE MOTEUR	YEAR ANNEE	BLOCK BLOC	CAMSHAFT ARBE A CAME	CYLINDER HEAD TÊLE CYLINDRIQUE	OIL GALLERY GALERIE D'HUILE	KIT NO. TROUSSE NO.
--	---------------	---------------	-------------------------	-----------------------------------	--------------------------------	------------------------

HYUNDAI | 6 Cylinder

2.5 L (2500 CC)	2001-99	(5) 260-315		(2) 260-147		
		(3) 261-146		(4) 260-315		
2.7 L (2700 CC)	2003-01	(5) 260-315		(4) 260-315		
		(3) 261-146		(2) 260-147		
3.0 L (2972 CC) - G6AT	1998-90	(5) 260-315		(2) 261-146		
		(1) 260-186		(2) 260-922		
		(2) 261-146		(2) 260-920		
		(2) 260-921				
		(3) 260-923				
3.0 L (3000 CC)	2001	(2) 261-146		(4) 260-315		
		(5) 260-315				
		(1) 260-186				

INFINITI | 4 Cylinder

2.0 L (1998 CC) - SR20DE	2002-91 G20	(6) 261-138		(4) 261-138		
		(1) 260-922				
		(6) 260-923				

INFINITI | 6 Cylinder

3.0 L (2960 CC) - VG30DE	1996-93 J30	(12) 261-138		(2) 261-118		
				(1) 260-924		
3.0 L (2983 CC) - VQ30DE	2001-96 I30			(2) 261-132		
				(2) 261-138		
3.3 L (3275 CC) - VG33E	2000-98 QX4	A/R261-138		A/R261-138		
3.5 L (3500 CC) - VQ35DE	1998	(2) 260-307				
3.5 L (3500 CC) - VQ35DE	2005-01 I35,G35,QX4			(2) 261-132		
				(2) 261-138		

INFINITI | 8 Cylinder

4.1 L (4130 CC) - VH41DE	2001-97 Q45	(3) 261-118		(2) 261-118		
		(6) 261-138		(2) 261-138		
		A/R261-146				
4.5 L (4494 CC)	2005-02 M45,Q45			(6) 261-138		
4.5 L (4494 CC) - VH45DE	1996-90 Q45	(6) 261-138				
				(2) 261-118		

IZUZU | 4 Cylinder

1.6 L (1588 CC)	1993-92 Inc Turbo	(6) 260-392		(4) 260-144		
		(1) 260-309		(2) 261-118		
		(2) 260-922		(1) 260-922		
2.3 L (2254 CC) - 4ZD1	1995-86	(6) 260-392		(1) 261-161	(2) 261-144	
		(1) 260-922		(2) 260-144	(2) 260-114	
					(5) 260-921	
2.6 L (2559 C) - AZE1	1997-88				(4) 260-309	
					Rocker Arm Shaft	
		(6) 260-392		(2) 260-144	(2) 261-114	
		(1) 260-922		(1) 261-161	(2) 260-309	
					(5) 260-921	
			(4) 260-309			
				Rocker Arm Shaft		

IZUMI® EXPANSION PLUGS

BOUCHON D'EXPANSION

ENGINE SIZE (C.I.D.) FORMAT DE MOTEUR	YEAR ANNEE	BLOCK BLOC	CAMSHAFT ARBE A CAME	CYLINDER HEAD TÊLE CYLINDRIQUE	OIL GALLERY GALERIE D'HUILE	KIT NO. TROUSSE NO.
--	---------------	---------------	-------------------------	-----------------------------------	--------------------------------	------------------------

IZUZU | 6 Cylinder

3.1 L (3137 CC) - CPC	1994-91	(3) 260-130				
		(6) 261-145 A/R260-922 (2) 260-923				
3.2 L (3165 CC) - 6VDI	2003-98		(1) 260-103		A/R260-922 (1) 260-111	
	1997-92	(2) 260-153	(1) 260-103		A/R260-922 (1) 260-111	
3.5 L (3500 CC) - 6VEI	2003-98		(1) 260-103		A/R260-922 (1) 260-111	

JAGUAR | 6 Cylinder

2.9 L (2900 CC)	1992-90	(1) 260-921		(1) 260-324 (2) 260-136		
3.2 L (3200 CC)	1994-90	(1) 260-921		(6) 260-145		
3.6 L (3590 CC)	1992-90	(1) 260-921		(6) 260-145		
4.0 L (3980 CC)	1997-90	(1) 260-921		(6) 260-145		
4.2 L (4235 CC)	1995-85	(9) 260-189		(5) 260-136		
		(2) 260-318				

JAGUAR | 12 Cylinder

6.0 L (5994 CC)		(2) 260-136		(2) 260-324 (14) 260-136		
-----------------	--	-------------	--	-----------------------------	--	--

JEEP | 4 Cylinder

2.4 L (148 CID)	2005-02	(4) 260-324		(2) 260-318		
2.5 L (150 CID)	2002-83	(3) 260-207	(1) 260-246	(1) 260-357		
	AMC Eng.	(1) 260-357 (4) 260-923		(4) 260-136		

JEEP | 6 Cylinder

3.7 L (226 CID)	2005-02	(8) 260-324		(2) 260-318		
4.0 L (242 CID)	2005-87	(4) 260-357	(1) 260-246	(2) 260-315 (1) 260-357	(2) 260-923	
		(4) 260-357 (1) 260-136	(1) 260-246	(2) 260-357	(2) 260-923	

JEEP | 8 Cylinder

4.7 L (285 CID)	2005-99	(1) 260-128		(2) 260-318		
		(10) 260-324		(1) 260-303		
5.2 L (318 CID)	1998-93	(1) 260-318	(1) 260-213	(4) 260-318	(1) 261-108	
		(9) 260-189	(1) 260-026		(1) 260-118	
5.9 L (360 CID)	1998	(1) 260-318	(1) 260-213	(4) 260-318	(1) 261-108	
		(9) 260-189			(4) 260-923	

LEXUS | 6 Cylinder

3.0 L (2999 CC) - ZJZGE	2005-92	(11) 261-146		(4) 261-118		
		(2) 261-126				
3.0 L (2999 CC) - IMZFE	2003-94			(8) 261-138		
3.3 L (2999 CC) - 3MZFE	2005-04					
4.5 L (477 CC) - IFZFE	1997-96	(9) 260-392		(2) 261-138		
		(2) 261-185				

LEXUS | 8 Cylinder

4.0 L (3966 CC) - IUZFE	2000-90			(8) 261-138		
4.3 L (4300 CC) - 3UZFE	2005-01					
4.7 L (4663 CC) - 2UZFE	2005-99	(8) 260-392		(8) 261-138		

papco EXPANSION PLUGS

BOUCHON D'EXPANSION

ENGINE SIZE (C.I.D.) FORMAT DE MOTEUR	YEAR ANNEE	BLOCK BLOC	CAMSHAFT ARBE A CAME	CYLINDER HEAD TÊLE CYLINDRIQUE	OIL GALLERY GALERIE D'HUILE	KIT NO. TROUSSE NO.
--	---------------	---------------	-------------------------	-----------------------------------	--------------------------------	------------------------

LINCOLN | 6 Cylinder

3.0 L (182 CID)	2005-00	(5) 260-327 A/R260-330 (1) 260-252 <i>Balance Shaft</i>		(1) 261-252		
3.8 L (232 CID)	1994-82	A/R260-327 A/R260-330 (4) 260-922 A/R 260-923	A/R260-336	(2) 260-189		

LINCOLN | 8 Cylinder

4.6 L (281 CID)	2005-93 <i>SOHC</i>	(2) 260-308 (2) 260-923 A/R260-327		A/R260-305 (6) 260-923		
	2005-93 <i>DOHC</i>	(2) 260-308 (1) 260-130 A/R260-327		(2) 260-318 (6) 260-923		
5.0 L (302 CID)	1992-77	A/R260-923 (1) 260-130 A/R260-327 A/R260-330	(1) 260-243 (1) 260-249	(7) 260-926	(3) 260-114 A/R260-922 (1) 260-130 (1) 260-129	
5.4 L (330 CID)	2005-98	(2) 260-308 (6) 260-327				

MAZDA | 4 Cylinder

1.5 L (1489 CC)	1998-96 <i>Protégé</i>	(3) 261-146 (6) 261-138				
1.6 L (1598 CC)	2003-99 <i>Protégé</i>	(4) 261-138 (4) 261-146		(1) 261-138		
1.6 L (1597 CC)	1995-96 <i>323, Miata, MX3</i>	A/R261-138 A/R261-146		A/R261-138		
1.8 L (1839 CC)	2005-90 <i>SOHC</i>	(4) 261-138 (4) 261-146		(1) 261-138		
	2005-90 <i>DOHC</i>	A/R261-138 (4) 261-146		A/R261-138		
2.0 L (1991 CC)	2003-93 <i>626, MX-6,</i>	(9) 261-138 (1) 261-146		(5) 260-128 (1) 261-138		
2.2 L (2184 CC)	1992-88 <i>626, MX-6</i>	(2) 260-315 (1) 261-138 (2) 261-146 (6) 261-161				
2.6 L (2606 CC)	1994-89 <i>MPV</i>	A/R260-315 (3) 261-138 A/R261-146 A/R261-161		(1) 261-161		

MAZDA | 6 Cylinder

1.8 L (1845 CC)	1995-92 <i>MX-3</i>			(1) 261-161		
2.3 L (2254 CC)	2002-00 <i>Millenia</i>			A/R261-146		
2.5 L (2497 CC)	2002-98 <i>626, Millenia</i>			(4) 260-128		

EXPANSION PLUGS

BOUCHON D'EXPANSION

ENGINE SIZE (C.I.D.) FORMAT DE MOTEUR	YEAR ANNEE	BLOCK BLOC	CAMSHAFT ARBE A CAME	CYLINDER HEAD TÊTE CYLINDRIQUE	OIL GALLERY GALERIE D'HUILE	KIT NO. TROUSSE NO.
--	---------------	---------------	-------------------------	-----------------------------------	--------------------------------	------------------------

MAZDA | 6 Cylinder (Cont'd)

2.5 L (2497 CC)	2002-93			(4) 261-161		
	626, MX-6, Millenia					
3.0 L (2954 CC)	1998-91	(2) 261-146 (3) 261-186 AR260-923		(2) 261-138		
	MPV					
	1995-90	(3) 261-186 (1) 261-146 AR260-923		(4) 261-138 A/R260-924 A/R260-922 A/R260-926 A/R260-923		
	929 (DOHC)					

MAZDA TRUCK | 4 Cylinder

2.2 L (2184 CC)	1993-87	(2) 260-315		(1) 261-161		
		(1) 261-138				
		(2) 261-146				
		(6) 261-161				
2.3 L (2295 CC)	1997-94	(1) 260-365				
2.6 L (2606 CC)	1993-89	A/R260-315		(1) 261-161		
		(3) 261-138				
		A/R261-146				
		A/R261-161				

MAZDA TRUCK | 6 Cylinder

3.0 L (2999 CC)	2005-94	(3) 260-311		(4) 261-318		
	B2000					
4.0 L (4016 CC)	2000-94	(1) 260-249				
	B4000					
	1994-91	(2) 260-249				
	Navajo					

MERCURY | 4 Cylinder

1.6 L (1598 CC)	1994-91	(2) 261-114				
		(3) 261-146				
		AR261-138				
1.8 L (110 CID)	1996-91	(4) 261-146		A/R261-118		
		(2) 261-114				
		(4) 261-138				
1.9 L (116 CID)	1996-91	(4) 260-324	(1) 260-136	(2) 260-327		
		(1) 261-114		A/R261-114		
		(1) 260-249		A/R261-158		
		(3) 260-922		(3) 260-923		
		(3) 260-921				
2.0 L (122 CID)	2000-97	(4) 260-324		(2) 260-327	(1) 260-318	
		(1) 260-249		A/R261-158	Intake Manifold	
		(4) 261-114				
	2000-95	(4) 260-324		(1) 260-171		
		(1) 260-249		(2) 260-923		
2.0 L (122 CID) - 3	2002-99	(4) 260-324		(1) 260-171		
		(1) 260-249		(2) 260-923		
2.3 L (140 CID)	1994-84	(4) 260-339	(1) 260-252	(3) 260-923		
		(1) 260-249		(4) 260-327		
		AR260-922				
		(4) 260-207				
		(5) 260-926				

papeco EXPANSION PLUGS

BOUCHON D'EXPANSION

ENGINE SIZE (C.I.D.) FORMAT DE MOTEUR	YEAR ANNEE	BLOCK BLOC	CAMSHAFT ARBE A CAME	CYLINDER HEAD TÊLE CYLINDRIQUE	OIL GALLERY GALERIE D'HUILE	KIT NO. TROUSSE NO.
--	---------------	---------------	-------------------------	-----------------------------------	--------------------------------	------------------------

MERCURY | 4 Cylinder (Cont'd)

2.3 L (140 CID)	1994-84	A/R260-922		(3) 260-922	(1) 260-124	
	<i>Exc: Topaz (HSC)</i>	A/R260-923 (1) 260-365 (1) 260-366 (1) 260-243 (4) 260-327 (4) 260-330				

MERCURY | 6 Cylinder

3.0 L (182 CID)	2005-86	(4) 260-922 (2) 260-923 (5) 260-327 A/R260-336 A/R260-330 (1) 260-252 <i>Balance Shaft</i>	(1) 260-252	(5) 260-318	(6) 260-922 A/R260-923 (1) 260-124 <i>Timing Hole</i>	
	1998 <i>Villager</i>		(1) 260-252		(1) 260-124 <i>Timing Hole</i>	
3.8 L (232 CID)	2000-95	A/R260-327 A/R260-189 A/R260-330 (4) 260-922 A/R260-923	A/R260-336	(2) 260-189		
	1994-82	A/R260-327 A/R260-330 (4) 260-922 A/R260-923	A/R260-336	(2) 260-189		
4.0 L (244 CID)	2001-98 <i>Mountaineer</i>	A/R260-330 A/R260-327				

MERCURY | 8 Cylinder

4.6 L (281 CID)		(2) 260-308 (2) 260-923 A/R260-327			A/R260-305 (6) 260-923	
5.0 L (302 CID)	2001-68	A/R260-923 (1) 260-130 A/R260-327 A/R260-330	(1) 260-243 (1) 260-249	(7) 260-926	(3) 260-114 A/R260-922 (1) 260-130 (1) 260-129	

MITSUBISHI | 4 Cylinder

1.5 L (1468 CC)	2002-85	(8) 261-146		(2) 261-146		
		(1) 260-922 (1) 260-923		(4) 260-920 (2) 260-921 (2) 260-922		
1.6 L (1597 CC)	1992-85	(7) 261-146		(1) 261-161		
		(8) 261-161 (1) 260-920 (1) 260-923		(2) 260-921 (1) 260-920 (1) 260-922		
1.8 L (1754 CC)	1994-93 <i>Eclipse</i>	(7) 261-146		(1) 261-161		
		(8) 261-161 (1) 260-920 (1) 260-923		(1) 260-920 (1) 260-922		

napco EXPANSION PLUGS

BOUCHON D'EXPANSION

ENGINE SIZE (C.I.D.) FORMAT DE MOTEUR	YEAR ANNEE	BLOCK BLOC	CAMSHAFT ARBE A CAME	CYLINDER HEAD TÊLE CYLINDRIQUE	OIL GALLERY GALERIE D'HUILE	KIT NO. TROUSSE NO.
--	---------------	---------------	-------------------------	-----------------------------------	--------------------------------	------------------------

mitsubishi | 4 Cylinder (Cont'd)

1.8 L (1754 CC)	1992-90	(7) 261-146		(1) 261-146		
	<i>Eclipse</i>	(1) 260-920		(1) 260-920		
		(1) 260-921		(1) 260-922		
		(1) 260-923				
1.8 L (1834 CC)	2002-92	(9) 261-146		(1) 261-146		
	<i>Expo, Mirage</i>	(2) 260-922		(1) 260-922		
2.0 L (2000 CC)	2005-02	(10) 260-146		(1) 261-146		
	1999-84 <i>Passenger Car</i>	(9) 260-146		(1) 261-146		
(9) 261-161			(1) 261-161			
(2) 260-920			(10) 260-921			
(1) 260-921			(1) 260-922			
2.4 L (2350 CC)	1999-87 <i>Pick-up, Van, Montero</i>	(9) 261-146		(1) 261-161		
		(1) 260-923		(1) 260-922		
		(2) 260-920				
2.4 L (2351 CC)	2005-92 <i>Passenger Car</i>	(7) 261-146		(2) 261-146		
		(2) 261-161		(9) 260-921		
		(2) 260-920				
		(1) 260-923				

mitsubishi | 6 Cylinder

3.0 L (2960 CC)	2004-97 <i>Montero Sport</i>	(1) 260-924				
		(5) 260-315		(2) 260-318		
		(2) 261-146				
3.0 L (2972 CC)	2005-88	(5) 260-315		(4) 260-315		
		(2) 261-146		(2) 261-146		
		(1) 261-165		(6) 260-920		
		(3) 260-923		A/R260-921		
		(2) 260-922		(2) 260-922		
		(1) 260-921				
3.5 L (3490 CC)	1996-94	(5) 260-315		(4) 260-315		
		(2) 261-146		(4) 260-920		
		(1) 261-165		(18) 260-921		
		(3) 260-923				
3.5 L (3497 CC)	2004-97	(5) 260-315		(2) 260-318		
		(2) 261-146				
		(1) 261-165				
3.8 L (3828 CC)	2005-04	(1) 261-265		(3) 261-146		
				(2) 260-318		

NISSAN | 4 Cylinder

1.6 L (1590 CC) - E16i	1988-83 <i>ER</i>	(1) 261-132		A/R260-108		
		(8) 261-138				
		(1) 261-146				
1.6 L (1590 CC) - E16S	1987-84 <i>Sentra</i>	(1) 261-132		(1) 260-108		
		(8) 261-138		(1) 260-118		
		(1) 261-146				
1.6 L (1590 CC) - GA16i	1990-89	(8) 261-138		(2) 260-108		
				(4) 260-923		
				(1) 260-924		
1.6 L (1597 CC) - GA16DE	1999-91	(9) 261-138		(2) 260-108		

napco EXPANSION PLUGS

BOUCHON D'EXPANSION

ENGINE SIZE (C.I.D.) FORMAT DE MOTEUR	YEAR ANNEE	BLOCK BLOC	CAMSHAFT ARBE A CAME	CYLINDER HEAD TÉLE CYLINDRIQUE	OIL GALLERY GALERIE D'HUILE	KIT NO. TROUSSE NO.
--	---------------	---------------	-------------------------	-----------------------------------	--------------------------------	------------------------

NISSAN | 4 Cylinder (Cont'd)

1.8 L (1809 CC)	2005-00	(8) 261-138		(1) 260-924 (4) 260-118		
1.8 L (1809 CC) - CA18DE	1989-88	(9) 261-138		A/R260-108 (1) 260-924 (1) 260-926		
2.0 L (1998 CC) - SR20DE	2002-91	(6) 261-138 (1) 260-922 (6) 260-923		(4) 260-138		
2.4 L (2389 CC) - KA24DE	2001-91	(5) 261-161 (2) 260-922		(2) 261-138		
2.4 L (2389 CC) - KA24E	1992-89	(6) 261-161		(1) 261-146 (4) 260-924		

NISSAN | 6 Cylinder

3.0 L (2960 CC) - V630	1989-84	(12) 261-138		(1) 261-138 (1) 260-923		
3.0 L (2960 CC) - VG30DE	1996-90	(1) 261-138		(2) 260-118 (1) 260-924		
3.0 L (2960 CC) - VG3SETT <i>Turbo</i>	1996-90	(12) 261-138		(5) 260-924		
3.0 L (2960 CC) - VG30E	1998-95	(12) 261-138		(1) 261-138 (1) 260-923		
	1994-92	(2) 260-307 (12) 261-138		(1) 261-138 (1) 260-923		
	1991-85	(2) 260-307		(12) 261-138 (1) 260-923		
3.0 L (2960 CC) - VG30T <i>Turbo</i>	1989-84	(12) 261-138		(1) 261-138 (1) 260-923		
3.0 L (2988 CC) - VQ30DE	2001-95			(2) 261-132 (2) 261-138		
3.3 L (3300 CC) - VG33E	2002-99	A/R 261-138		A/R261-138		
3.5 L (3500 CC) - VQ35DE	2005-02			(2) 261-132		

NISSAN TRUCK | 4 Cylinder

2.4 L (2389 CC) - KAZ24DE	2004-98	(5) 261-161 (2) 260-922		(2) 261-138 (2) 261-138		
2.4 L (2389 CC) - KA24E	1997-90	(6) 261-161		(1) 261-146 (4) 260-924		
2.4 L (2389 CC) Z24 <i>ER</i>	1989-86	A/R261-161		(1) 261-146 (2) 260-926		

NISSAN TRUCK | 6 Cylinder

3.0 L (2960 CC) - VG30	1989-96	(2) 260-307 (12) 261-138		(1) 261-146 (1) 260-923		
3.0 L (2960 CC) - VG30E	1995-90	(12) 260-307		(1) 261-138 (1) 260-923		
3.3 L (3300 CC) - VG33E	2004-96 1998-96 <i>Block</i>	A/R261-138 (2) 260-307		A/R261-138		
3.5 L (3500 CC) - VQ35DE	2004-01			(2) 261-132 (2) 261-138		

papeco® EXPANSION PLUGS

BOUCHON D'EXPANSION

ENGINE SIZE (C.I.D.) FORMAT DE MOTEUR	YEAR ANNEE	BLOCK BLOC	CAMSHAFT ARBE A CAME	CYLINDER HEAD TÊLE CYLINDRIQUE	OIL GALLERY GALERIE D'HUILE	KIT NO. TROUSSE NO.
--	---------------	---------------	-------------------------	-----------------------------------	--------------------------------	------------------------

OLDSMOBILE 4 Cylinder						
2.2 L (134 CID) - 4	1996-93	(4) 261-171			(1) 261-145 (1) 260-922 (2) 260-924	
2.3 L (138 CID) - D,3	1995-89	A/R260-922		(1) 260-145 (2) 261-118 (2) 260-921 A/R260-923 (1) 260-922		260-418
2.3 L (140 CID)	1994-89			(1) 260-145 (1) 261-118		
2.4 L (146 CID) - T	2001-96	(1) 260-922		(1) 260-318		
2.5 L (151 CID)	1992-78	(1) 260-222 (3) 261-165	(1) 260-372	(2) 260-130 (1) 260-210 (4) 260-303 (1) 261-165	(1) 261-108 (2) 260-120 (1) 260-923	260-400
OLDSMOBILE 6 Cylinder						
2.8 L (173 CID)	1989-79	(6) 261-145 (1) 260-136 (2) 260-922	(1) 260-902	(2) 260-315 A/R260-922	(1) 260-902 (2) 260-901 (2) 260-923	260-407
3.0 L (181 CID)	1988-85	A/R260-156 (4) 260-150 (4) 260-327 (4) 260-330	(1) 260-224	(4) 260-150	A/R 260-126 A/R 260-901	260-410
3.1 L (189 CID) - D	1995-90	(6) 261-145 (3) 260-922	(1) 260-372		(2) 260-921 (3) 260-923	
<i>Silhouette Van</i>						
3.1 L (189 CID) - M	1999-93	(1) 260-126 (4) 260-902 (1) 260-901 (1) 260-923	(1) 260-372	(4) 260-315 (1) 260-902		
3.1 L (189 CID) - T	1993	(6) 260-145 (2) 260-902 A/R260-923	(1) 260-372	A/R260-315	A/R 260-902 (2) 260-901	
<i>Cutlass Supreme</i>						
3.3 L (204 CID)	1993-89	(6) 260-327 (4) 260-330	(1) 260-224	(4) 260-150 A/R260-156	(1) 260-923 A/R260-922 A/R260-902	
3.4 L (207 CID) - E	2004-96	(6) 261-145		(4) 260-315		
3.4 L (207 CID) - X	1997-91	(6) 261-145 (2) 260-922	(1) 260-372	(2) 261-145 (2) 260-922	(2) 260-921 (2) 260-922	
<i>Cutlass Supreme</i>						
3.5 L (214 CID) - H	2002-99			(2) 260-318		
<i>Intrigue</i>						
	2002-01			(2) 260-318		
3.8 L (231 CID) - I	2000-95	(1) 260-315				
3.8 L (231 CID) - 1,3,C,K,L	2000-88	(1) 260-224 A/R 260-921 (3) 260-922 (6) 260-327 A/R 260-183	(1) 260-224	(4) 260-150 A/R260-156	(2) 260-120	260-410
<i>w/Balance Shaft</i>						

papco EXPANSION PLUGS

BOUCHON D'EXPANSION

ENGINE SIZE (C.I.D.) FORMAT DE MOTEUR	YEAR ANNEE	BLOCK BLOC	CAMSHAFT ARBE A CAME	CYLINDER HEAD TÊLE CYLINDRIQUE	OIL GALLERY GALERIE D'HUILE	KIT NO. TROUSSE NO.
--	---------------	---------------	-------------------------	-----------------------------------	--------------------------------	------------------------

OLDSMOBILE | 6 Cylinder (Cont'd)

4.3 L (262 CID)	2001-94	(8) 260-186 (3) 260-922	(1) 260-372	(1) 260-922 A/R260-923	(3) 260-125 (1) 260-124	
	1993-91	(8) 260-186 (1) 260-922	(1) 260-372	(1) 260-922 A/R260-923	(3) 260-125 (1) 260-124	

OLDSMOBILE | 8 Cylinder

4.0 L (244 CID)	2003-95		(2) 260-318 (3) 260-921 (1) 260-922			
5.0 L (305 CID)	1992-77	(2) 260-186 (2) 260-922	(1) 260-240 (1) 260-372 (1) 260-372		(3) 260-115 A/R260-922 A/R260-901 A/R260-902	
5.0 L (307 CID)	1990-80	(6) 260-177 (6) 260-327	(1) 260-240 (1) 260-372 (1) 260-372	(4) 260-318	(1) 260-138 A/R260-923 (1) 260-924	260-413
5.7 L (350 CID) - 7	1992	(8) 260-186	A/R260-372	(1) 260-923	(3) 260-115 (2) 260-902 (2) 260-922	

PLYMOUTH | 4 Cylinder

1.5 L (1468 CC)	1994-85 CoH, Vista, Champ, Arrow	(8) 261-146		(2) 261-146		
		(1) 260-922		(4) 260-920		
		(1) 260-923		(2) 260-922		
1.6 L (1597 CC)	1990-89 COH (Inc: Turbo)	(7) 261-146		(1) 261-161		
		(1) 260-920		(2) 260-922		
		(1) 260-923				
1.8 L (1834 CC)	1988-85 Colt (Turbo)	(7) 261-146		(1) 261-161		
		(9) 260-923		(1) 260-920		
				(3) 260-922		
1.8 L (1834 CC)	1994-93 Laser	(7) 261-146		(1) 261-161		
		(1) 260-920		(1) 260-920		
		(1) 260-921 (1) 260-923		(1) 260-922		
1.8 L (1834 CC)	1992-90 Laser	(7) 261-146		(1) 261-146		
		(1) 260-920		(1) 260-920		
		(1) 260-921 (1) 260-923		(1) 260-922		
1.8 L (1834 CC)	1994-89 Colt, Vista	(9) 261-146		(1) 261-146		
		(2) 260-922		(1) 260-922		
2.0 L (122 CID)	2001-95 Breeze, Neon	(4) 260-324		(2) 260-318		
		(1) 260-311		(6) 260-303		
	1994-90 Laser Turbo	(7) 261-146		(1) 261-146		
		(1) 260-923 (2) 260-920		(2) 261-161 (9) 260-921 (3) 261-121		
1994-90 Laser w/o Turbo	(9) 261-146 (2) 260-920 (1) 260-923		(1) 261-146 (9) 260-921 (3) 261-121			

papco® EXPANSION PLUGS

BOUCHON D'EXPANSION

ENGINE SIZE (C.I.D.) FORMAT DE MOTEUR	YEAR ANNEE	BLOCK BLOC	CAMSHAFT ARBE A CAME	CYLINDER HEAD TÊLE CYLINDRIQUE	OIL GALLERY GALERIE D'HUILE	KIT NO. TROUSSE NO.
--	---------------	---------------	-------------------------	-----------------------------------	--------------------------------	------------------------

PLYMOUTH | 4 Cylinder (Cont'd)

2.0 L (2000 CC)	1991-84	(9) 261-146		(1) 261-146			
	<i>Vista</i>	(9) 261-161		(1) 261-161			
		(1) 260-921		(9) 261-921			
		(1) 260-923					
		(2) 260-920					
2.2 L (135 CID)	1994-81	(5) 260-186		(2) 260-318	(4) 260-311	260-434	
		(1) 260-193		(1) 260-186	(4) 260-128		
		(1) 260-922		(2) 260-128			
2.4 L (148 CID)	2000-96	(2) 260-231		A/R260-923			
		(2) 260-189		(2) 260-128			
2.4 L (235 CID)	1994-92	(1) 261-146		(2) 261-146			
		(2) 261-161		(9) 260-921			
		(2) 260-920					
		(1) 260-923					
		(1) 260-924					
2.5 L (153 CID)	1995	(5) 260-186		(2) 260-318	(4) 260-311		
		(1) 260-193		(2) 260-128	(4) 260-128		
		(1) 260-922		A/R260-923			
	<i>Acclaim</i>	1994-93	(5) 261-186		(2) 260-318	(4) 260-311	
			(1) 260-246		(1) 260-357	(4) 260-128	
			(3) 260-207		(4) 260-136		
			(1) 260-193		(2) 260-128		
	1994-93	<i>Exc: Acclaim</i>	(5) 260-186		(2) 260-318	(4) 260-311	
			(1) 260-193		(2) 260-128	(4) 260-128	
	1992-86		(1) 260-922		A/R260-923		
			(5) 260-186		(2) 260-318	(4) 260-311	
			(1) 260-193		(2) 260-128	(4) 260-128	
		(1) 260-922		A/R260-923			

PLYMOUTH | 6 Cylinder

3.0 L (181 CID)	2000-87	(5) 260-315		(2) 261-146	(1) 260-923	260-430
		(2) 261-146		(2) 260-920		
		(1) 261-165		(2) 260-922		
		(2) 260-921				
		(2) 260-922				
		(1) 260-923				
3.3 L (201 CID)	2000-94	(8) 260-189	(1) 260-388	(4) 260-318	(9) 260-311	260-436
					(2) 260-126	
	1993-90	(8) 260-189	(1) 260-388	(4) 260-318	(9) 260-311	260-432
		(8) 260-186			(2) 260-126	
3.5 L (215 CID)	1997	(8) 260-189		(2) 260-318	(4) 260-303	260-432
		(5) 260-311				
		(8) 260-126				
3.5 L (215 CID) - G	2001-99	260-189		(4) 260-318	(3) 260-311	
3.8 L (230 CID)	1999-94	(8) 260-189	(1) 260-388	(4) 260-318	(9) 260-311	260-432
		(1) 260-128			(2) 260-126	
	1993-86	(8) 260-189	(1) 260-388	(4) 260-318	(9) 260-311	
					(2) 260-126	

papeco EXPANSION PLUGS

BOUCHON D'EXPANSION

ENGINE SIZE (C.I.D.) FORMAT DE MOTEUR	YEAR ANNEE	BLOCK BLOC	CAMSHAFT ARBE A CAME	CYLINDER HEAD TÊLE CYLINDRIQUE	OIL GALLERY GALERIE D'HUILE	KIT NO. TROUSSE NO.
--	---------------	---------------	-------------------------	-----------------------------------	--------------------------------	------------------------

PONTIAC | 4 Cylinder

1.6 L (98 CID)	1987-81 <i>T1000</i>	(7) 261-145	(1) 260-307		(1) 261-108	
1.6 L (98 CID) - 6	1993-88 <i>Lemans</i>	(1) 261-132		(1) 261-114 (1) 261-132		
2.0 L (122 CID) - H	1994-92				(2) 260-921	
2.0 L (122 CID) - K	1991-87	(4) 261-145		(2) 260-142	AR260-922 (1) 260-923	260-418
2.0 L (122 CID) - M	1990-87 <i>Turbo</i>	(4) 261-145			(2) 260-921 AR260-922 (1) 260-923	260-418
2.2 L (134 CID) - 4	2002-95	(4) 261-171		(1) 261-145	(2) 260-922 (2) 260-924	
2.3 L (138 CID) - D,3	1995-89	AR260-922		(1) 260-145 (2) 261-118	(2) 260-921 (1) 260-922 AR260-923	
2.3 L (140 CID)	1994-89			(1) 260-145 (2) 261-118		
2.4 L (146 CID) - T	2002-96	(1) 260-922		(1) 260-318 (2) 260-130		
2.5 L (151 CID)	1991-77	(1) 260-222 (3) 261-145	(1) 260-372	(1) 261-165 (1) 260-210 (4) 263-548	(2) 260-120 (1) 261-108 (1) 260-923	260-400

PONTIAC | 6 Cylinder

2.8 L (173 CID)	1989-79	(6) 261-145 (1) 260-136 (2) 260-922		(2) 260-315 (1) 260-902	(1) 260-902 AR260-922 (2) 260-901 (2) 260-923	260-407
3.0 L (181 CID)	1987-85	AR260-156 (4) 260-150 (4) 260-327 (4) 260-330	(1) 260-224	(4) 260-150	AR260-126 AR260-901	260-410
3.1 L (189 CID) - D	1995-90 <i>Transport Van</i>	(6) 261-145 (3) 260-922	(1) 260-372		(2) 260-921 (3) 260-923	
3.1 L (189 CID) - J	2003-00	(1) 261-145		AR260-315		
3.1 L (189 CID) - M	1999-94	(1) 260-126 (4) 260-902 (1) 260-901 (1) 260-923	(1) 260-372	(4) 260-315 (1) 260-902		
3.1 L (189 CID) - T	1994-88	(6) 260-145 (2) 260-902 AR260-923 (6) 260-145 (2) 260-922	(1) 260-372	AR260-315 AR260-315 (1) 260-902	AR260-902 (2) 260-901 AR260-136 AR260-902 AR260-922 (2) 260-901 AR260-923	
3.3 L (204 CID)	1993-92	(6) 260-327 (4) 260-330	(1) 260-224	(4) 260-150 AR260-156	(1) 260-923 AR260-922 AR260-902	

papeco EXPANSION PLUGS

BOUCHON D'EXPANSION

ENGINE SIZE (C.I.D.) FORMAT DE MOTEUR	YEAR ANNEE	BLOCK BLOC	CAMSHAFT ARBE A CAME	CYLINDER HEAD TÊLE CYLINDRIQUE	OIL GALLERY GALERIE D'HUILE	KIT NO. TROUSSE NO.
--	---------------	---------------	-------------------------	-----------------------------------	--------------------------------	------------------------

PONTIAC | 6 Cylinder (Cont'd)

3.4 L (207 CID) - E	2005-96	(6) 261-145	(1) 260-372	(4) 260-315		
	1995-93	(6) 261-145				
	<i>Firebird</i>	(3) 260-921				
		(6) 260-922 (2) 260-923				
3.4 L (207 CID) - X	1997-91	(6) 261-145 (2) 260-922	(1) 260-372	(2) 261-145 (2) 260-922	(2) 260-921 (2) 260-922	
3.5 L (211 CID)	2005		(1) 260-372	(2) 260-315	(1) 260-126	
3.8 L (231 CID) - 1,2,4	2005-95	(1) 260-315				
	<i>w/ Balance Shaft</i>					
3.8 L (231 CID) - 1,3,7,C,K,L	2005-88	(1) 260-224	(1) 260-224	(4) 260-150 A/R260-156	(2) 260-120	260-410
	<i>w/ Balance Shaft</i>	A/R260-921				
		(3) 260-921				
		(6) 260-327 A/R260-183				

PONTIAC | 8 Cylinder

4.6 L (281 CID)	2005-04			(2) 260-318		
5.0 L (305 CID)	1992-77	(8) 260-186	(1) 260-240		(3) 260-115	260-425
		(2) 260-922	(1) 260-372 (1) 260-372		A/R260-921 A/R260-922	
5.0 L (307 CID)	1989-81	(6) 260-177	(1) 260-240	(4) 260-318	(1) 260-138	
		(6) 260-327	(1) 260-372 (1) 260-372		A/R260-923 (1) 260-924	
5.7 L (350 CID) - 8	1992-87	(2) 261-165	A/R260-372	(1) 260-923	(3) 260-115	260-425
		(2) 260-186			(1) 260-113 (2) 260-121 (5) 260-922	
5.7 L (350 CID) - G	2005-98	(1) 260-315		(2) 260-318	(1) 260-126	
5.7 L (350 CID) - P	1997-93	(8) 260-186	(1) 260-372	(2) 260-922	(3) 260-115	
		(1) 260-922		(1) 260-923	(1) 260-901	
6.0 L (364 CID)	2005	(1) 260-315		(2) 260-318	(1) 260-126	

PORSCHE | 4 Cylinder

2.0 L (1983 CC)	1982-80	(5) 261-150				
	<i>Inc Turbo</i>					
2.5 L (2475 CC)	1989-83	(2) 260-315				
2.7 L (2688 CC)	1989	(2) 260-315				
3.0 L (2983 CC)	1994-92	(2) 260-315				
3.0 L (2999 CC)	1995-81	(2) 260-315				

SAAB | 4 Cylinder

2.0 L (1985 CC) B201, IL	1993-85	(3) 260-189		(1) 261-132		
	900					
2.0 L (1985 CC) B202	1993-86	(2) 260-189		(3) 261-105		
	9000	(2) 261-132		(2) 261-132		
2.0 L (1985 CC) B2341	1998-94	(1) 261-132		(3) 261-105		
	900			(2) 261-132		
2.1 L (2119 CC)	1994-91	(1) 261-132		(2) 261-132		
		(2) 260-189		(3) 261-105		
2.3 L (2290 CC)	1998-90	(1) 261-132		(3) 261-105		
				(2) 261-132		

SAAB | 6 Cylinder

2.5 L (2498 CC)	1997-94		(8) 260-143			
3.0 L (2961 CC)	1997-95		(8) 260-143			

papco EXPANSION PLUGS

BOUCHON D'EXPANSION

ENGINE SIZE (C.I.D.) FORMAT DE MOTEUR	YEAR ANNEE	BLOCK BLOC	CAMSHAFT ARBE A CAME	CYLINDER HEAD TÊLE CYLINDRIQUE	OIL GALLERY GALERIE D'HUILE	KIT NO. TROUSSE NO.
SATURN 4 Cylinder						
1.9 L (116 CID)	2002-91 SOHC DOHC		(1) 260-345			
SUBURU 4 Cylinder						
1.8 L (1781 CC)	1994-85	(3) 260-922		(2) 260-117 (7) 260-117		
SUZUKI 4 Cylinder						
1.3 L (1298 CC)	2001-89 Swift SOHC	(1) 260-921 (2) 260-922 (2) 260-923		(4) 260-133		
	1997-89 Swift			(1) 260-133 (1) 261-105		
	1995-89 Samurai	(1) 260-921 (2) 260-922 (2) 260-923		(1) 260-141 (1) 261-105 (4) 260-133		
	1994-89 Swift DOHC	(1) 260-921 (2) 260-922 (2) 260-923		(1) 260-141 (5) 260-147 (1) 260-324 (6) 260-921		
1.6 L (1590 CC)	2003-99 Vitara	(4) 260-147		(1) 260-141 (3) 260-133		
	1995-95 Esteem	(4) 260-147 (1) 260-921 (2) 260-922 (2) 260-923		(1) 260-147 (3) 260-133 (1) 260-924		
	1998-89 Sidekick (2 Valve)	(4) 260-147 (1) 260-921 (2) 260-922 (2) 260-923		(3) 260-133 (1) 260-105		
	Sidekick (4 Valve)	(4) 260-147 (1) 260-921 (2) 260-922 (2) 260-923		(1) 260-147 (3) 260-133 (1) 260-924		
1.8 L (1790 CC)	2002-99 Esteem	(1) 260-147				
1.8 L (1840 CC)	1998-96 Sidekick	(1) 260-147 (5) 260-921				
2.0 L (2000 CC)	2003-99 Vitara Aerio, Aerio SX	(4) 260-147				
SUZUKI 6 Cylinder						
2.5 L (2500 CC)	2005-99 Grand Vitara XL-7	(7) 260-147				
2.7 L (2700 CC)	2005-01 Grand Vitara XL-7	(7) 260-147				

papco EXPANSION PLUGS

BOUCHON D'EXPANSION

ENGINE SIZE (C.I.D.) FORMAT DE MOTEUR	YEAR ANNEE	BLOCK BLOC	CAMSHAFT ARBE A CAME	CYLINDER HEAD TÊLE CYLINDRIQUE	OIL GALLERY GALERIE D'HUILE	KIT NO. TROUSSE NO.
--	---------------	---------------	-------------------------	-----------------------------------	--------------------------------	------------------------

TOYOTA | 4 Cylinder

1.5 L (1456 CC) - 3E	1990-87	(6) 261-138		(1) 261-161		
		(1) 261-146				
		(2) 261-126				
1.5 L (1456 CC) - 3EE	1994-90	(2) 261-126		(1) 261-161		
		(6) 261-138				
		(1) 261-146				
1.5 L (1497 CC) - 5EFE	1999-96	(2) 261-126		(2) 261-126		
		(6) 261-138		(2) 261-132		
	1995-92	(2) 261-122		(1) 261-126		
		(6) 261-138		(2) 261-132		
1.6 L (1587 CC) - 4AFE	1997-94	(6) 261-146		(1) 261-126		
		(1) 261-161		(3) 261-132		
		(2) 260-923		(1) 260-923		
1.6 L (1587 CC) - 4AFE	1993-88	(6) 261-146		(3) 261-132		
		(1) 261-161		(1) 260-923		
		(2) 260-923				
1.6 L (1587 CC) - 4AGE	1991-89	(1) 261-161				
		(6) 261-146				
		(2) 260-923				
1.8 L (1762 CC) - 2ZZGE	2005-00			(1) 261-114		
1.8 L (1762 CC) - 7AFE	1997-93	(6) 261-146		(1) 261-126		
		(1) 261-161		(3) 261-132		
				(1) 260-923		
2.0 L (1998 CC) - 3SGTE	1995-88	(8) 261-146		(2) 261-114		
		(1) 261-161		(1) 261-138		
		(2) 260-923				
		(1) 260-921				
2.0 L (2000 CC) - 3SFE	2000-86	(8) 261-146		(2) 261-132		
		(1) 261-161				
		(1) 260-921				
		(2) 260-922				
		(1) 260-923				
2.2 L (2164 CC) - 5SFE	2001-90	(8) 261-146		(2) 261-132		
		(1) 261-161				
		(4) 260-923				
2.2 L (2164 CC) - 5SNFE	2001-00	(8) 261-146				
		(1) 261-161				
2.4 L (2366 CC) - 22R	1990-81	(6) 261-161		(1) 260-922		
		(2) 260-923				
2.4 L (2366 CC) - 22RE	1990-81	(6) 261-161		(1) 260-922		
		(2) 260-923				
2.4 L (2438 CC) - 2RZFE	2004-95	(8) 260-392				
		(1) 261-138				
2.4 L (2438 CC) - 2TZFE	1996-94	(1) 261-138				
		(8) 260-392				
		(1) 261-114				
	1993-91	(1) 261-114				
		(1) 261-138				
		(8) 261-146				
		(1) 261-161				

papco EXPANSION PLUGS

BOUCHON D'EXPANSION

ENGINE SIZE (C.I.D.) FORMAT DE MOTEUR	YEAR ANNEE	BLOCK BLOC	CAMSHAFT ARBE A CAME	CYLINDER HEAD TÊLE CYLINDRIQUE	OIL GALLERY GALERIE D'HUILE	KIT NO. TROUSSE NO.
--	---------------	---------------	-------------------------	-----------------------------------	--------------------------------	------------------------

TOYOTA | 4 Cylinder (Cont'd)

2.4 L (2438 CC) - 2TZFE	1997-94	(8) 260-392 (1) 261-138 (1) 261-114				
2.7 L (2694 CC) - 3RZFE	2004-94	(8) 260-392 (1) 261-138				

TOYOTA | 6 Cylinder

3.0 L (2954 CC) - 7MGE	1992-87	(1) 260-150 (1) 261-138 (7) 261-161 (2) 260-921 (1) 260-923				
3.0 L (2954 CC) - 7MGTE	1992-87	(7) 261-161 (1) 260-150 (1) 261-138 (2) 260-921 (1) 260-923				
3.0 L (2959 CC) - 3VZE	1995-94	(11) 260-324 (11) 261-146 (6) 261-161 (1) 260-923		(2) 261-118 (4) 261-138		
	1993-89	(11) 261-146 (6) 261-161 (1) 260-923		(4) 261-138 (2) 261-118		
3.0 L (2967 CC) - 3VZFE	1993-92	(11) 261-146 (2) 260-923		(8) 261-138		
3.0 L (2995 CC) - 1MZFE	2005-94			(8) 261-138		
3.0 L (2995 CC) - 2JZGE	2001-94	(2) 261-126 (11) 261-146		(4) 260-118		
3.3 L (3300 CC) - 3MZFE	2005-04			(8) 261-138		
3.4 L (3378 CC) - 5VZFE	2005-95	(11) 260-324		(8) 261-138		
4.0 L (4000 CC) - 1GRFE	2005-03	(2) 260-392 (1) 261-118 (1) 261-126				
4.0 L (3956 CC) - 3FE	1992-98	(2) 260-142 (4) 261-126 (5) 261-185		(6) 261-126 (1) 261-185 (1) 260-924		
4.5 L (4477 CC) - 1FZFE	1997-93	(9) 260-392 (2) 261-185		(2) 261-138		

TOYOTA | 8 Cylinder

4.7 L (4663 CC) - 2UZFE	2005-98	(8) 260-392		(8) 261-138		
-------------------------	---------	-------------	--	-------------	--	--

VOLKSWAGEN | 4 Cylinder

1.6 L (1588 CC)	1992-82	(4) 261-150 (2) 260-118		(1) 260-143		
1.8 L (1780 CC)	1993-91	(2) 260-118		(1) 260-143		
	Fox	(4) 261-150				
	1990-87	(5) 261-150		(1) 260-143		
	Fox					
1.8 L (1780 CC) - 2H,JH	1993-85	(4) 261-150				
	Cabriolet	(2) 260-118				
1.8 L (1780 CC) - PG	1992-90	(4) 261-150		(1) 260-315		
	Corrade					

EXPANSION PLUGS

BOUCHON D'EXPANSION

ENGINE SIZE (C.I.D.) FORMAT DE MOTEUR	YEAR ANNEE	BLOCK BLOC	CAMSHAFT ARBE A CAME	CYLINDER HEAD TÊTE CYLINDRIQUE	OIL GALLERY GALERIE D'HUILE	KIT NO. TROUSSE NO.
--	---------------	---------------	-------------------------	-----------------------------------	--------------------------------	------------------------

VOLKSWAGEN | 4 Cylinder (Cont'd)

1.8 L (1788 CC) - ACC	1995-93	(5) 261-150		(1) 260-143		
	<i>Golf, Jetta</i>	(1) 260-118		A/R260-315		
1.8 L (1800 CC)	1998	(4) 261-150				
	<i>Beetle, Passat</i>					
1.9 L (1896 CC) - AAZ	1996-92	(4) 261-150				
	<i>Golf, Jetta, Passat</i>	(2) 260-118				
2.0 L (1984 CC) - 9A	1994-90	(1) 261-132				
	<i>16 Valve</i>	(5) 261-150				
2.0 L (1984 CC) - ABA	1999-93	(2) 260-118		(1) 260-143		
				A/R260-315		
2.1 L (2109 CC)	1992-86			(2) 260-143		
	<i>Vanagon, Transporter</i>					

VOLKSWAGEN | 5 Cylinder

2.4 L (2390 CC)	1995-93	(5) 261-150		(1) 260-315	(2) 260-143	
	<i>Eruovan, Transporter</i>	(1) 260-126				
		(1) 260-141				
2.5 L (2459 CC)	1996-92	(1) 260-141		(1) 260-315	(2) 260-143	
	<i>Eruovan, Transporter</i>	(5) 261-150				

VOLKSWAGEN | 6 Cylinder

2.8 L (2771 CC) - AHA	1998	(2) 260-111		(1) 261-150		
	<i>Passat</i>	(1) 260-315				
2.8 L (2792 CC) - AAA	1998-92	(1) 260-315		(1) 261-150		
	<i>Corrado, Golf, Jetta, Passat</i>	(2) 260-111				

VOLVO | 4 Cylinder

2.3 L (2316 CC) - B230F	1993-85	(8) 260-210		(4) 260-150		
		(1) 260-234		(2) 260-313		
2.3 L (2316 CC) - B230FD	1995-94	(8) 260-210		(4) 260-150		
		(1) 260-234		(2) 260-313		
2.3 L (2316 CC) - B230FT	1995-85	(8) 260-210		(4) 260-150		
		<i>Turbo</i>	(1) 260-234		(2) 260-313	
2.3 L (2316 CC) - B234F	1993-92	(8) 260-210		(2) 260-150		

VOLVO | 5 Cylinder

2.3 L (2319 CC) - B5234FT	1998			(4) 260-150		
		<i>Turbo</i>		(1) 260-313		
2.4 L (2442 CC) - B5254FS	1998-93			(4) 260-150		
				(1) 260-313		
2.4 L (2442 CC) - B5254FT	1998			(4) 260-150		
		<i>Turbo</i>		(1) 260-313		
2.4 L (2442 CC) - B5254T	1998			(4) 260-150		
		<i>Turbo</i>		(1) 260-313		

VOLVO | 6 Cylinder

2.9 L (2917 CC) - B6304F				(4) 260-150		
				(1) 260-313		
2.8 L (2849 CC) - B280F	1990-89			(6) 260-146		
				(2) 260-017		

SQUARE HEAD PIPE PLUGS

BOUCHONS DE TUYAU TETE CARRE

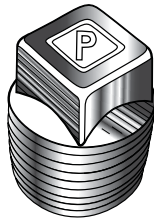

With LOCTITE® Vibra-Seal®

These forged steel pipe plugs are used as drain and filler plugs on all cars, trucks, tractors and stationary engines. Made with Dryseal American National Pipe Threads. For improved reliability 'Papco' Pipe Plugs feature LOCTITE® Vibra-Seal® pre-applied thread sealant.

Order by Stock Number

Standard Package 12 plugs

Iron Pipe Size	1/8 - 27 Thread	1/4 - 18 Thread	3/8 - 18 Thread	1/2 - 14 Thread	3/4 - 14 Thread
Stock No.	260-901	260-902	260-903	260-904	260-906
Approximate Diameter Small End	3/8"	1/2"	5/8"	7/8"	1"

SOCKET PIPE PLUGS

BOUCHONS DE TUYAU CREUX

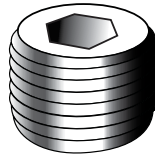

Hexagon Socket Steel Plugs with LOCTITE® Vibra-Seal® pre-applied thread sealant.

Order by Stock Number

Standard Package 12 plugs

Iron Pipe Size	1/8 - 27 Thread	1/4 - 18 Thread	3/8 - 18 Thread	1/2 - 14 Thread
Stock No.	260-921	260-922	260-923	260-924

EXPANSION PLUGS

BOUCHONS D'EXPANSION

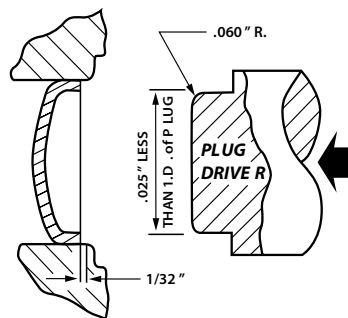

INSTALLATION INSTRUCTIONS Cup Type Expansion Plugs

- Hole must be clean, rust-free and have a smooth inside surface.
- A small amount of lubricant, such as light machine oil mixed with white lead, should prevent galling during insertion. (Some mechanics use a thin coat of sealant or gasket marker.)
- Plugs should be driven square to the hole and from the inside bottom of the cup. (A suggested design for the round plug driver is illustrated.)
- The open end of the plug should be driven approximately 1/32" beyond the face of the engine block.

MODE D'INSTALLATION Bouchons d'expansion assiette

- Le trou doit être propre, exempt de rouille et la surface intérieure doit être lisse.
- Une petite quantité de lubrifiant, tel que de l'huile légère à machine, mélangée avec du blanc de plomb empêchera les égratignures durant l'insertion. (Certains mécaniciens utilisent une mince couche d'obturator ou d'enduit à joint.)
- Les bouchons doivent être enfoncés carrément dans le trou par le fond intérieur de la cuvette. (Un modèle de chasse-bouchon rond est illustré.)
- Le bout ouvert du bouchon doit être enfoncé environ 1/32", au-delà de la face du bloc moteur.

Other product catalogues available ...

papco® Automotive and Industrial Fasteners No. 400

Automotive Aftermarket and Industrial Fasteners in Inch and Metric

- Cap Screws • Nuts • Washers • Screws
- Body shop Fasteners
- Wheel Parts • Brake lines
- Battery Parts • Grease Fittings

papco® Body Shop Fasteners No. BSF 1010

- Standard Steel Fasteners in Inch and Metric
- Body Bolts • Nuts • Clips
- Reveal Windshield Retainers
- Moulding Clips
- Trim Screws

Dominion Fluid Flow Components No. 6003

Fluid Flow Brass & Steel Fittings

- Compression • Flare
- Pipes • Valves
- Hose and Tubing

papcoFlex Brake Lines No. BL107

- Steel Brake Lines & Fittings
- Poly-V Brake Line
- 'No Tools Required' Fuel Line Repair
- Coolant & Transmission Fittings
- Merchandisers and Kits included

papco® Oil Drain Plugs No. DP1090

- Standard and Magnetic Drain Plugs with Gaskets
- Inch and Metric sizes
- Complete coverage for most Domestic and Import engines
- Oversized plugs for stripped holes
- Merchandisers and Kits included

papco® Wheel Parts WP-509

For Passenger Car and Light Truck

- Wheel Nuts
- Wheel Bolts
- Wheel Studs
- Wheel Spindle and Axle Nuts

